



Player One

Zeus 455M Pro Camera Manual

V1.0

Dec, 2024

Table of Contents

| | |
|--|----|
| Product Features | 3 |
| Technical parameters | 4 |
| Product Description..... | 5 |
| New Cutting-edge Design | 5 |
| Rear Adjustment 4 Point Sensor Tilt Plate..... | 6 |
| Deep Cooling..... | 7 |
| 512MB DDR3 Cache..... | 8 |
| STARVIS Technology | 9 |
| Full-Frame Format | 9 |
| Native 16bit ADC | 9 |
| Non-Amp-Glow..... | 10 |
| Type-C Data port and Power port | 11 |
| Standard Cable Usage..... | 12 |
| Cooling System and Anti-Dew Heater..... | 12 |
| Overvoltage and overcurrent protection mechanism | 13 |
| Performance | 14 |
| Dual Sampling Mode | 14 |
| Frame rate..... | 16 |
| Extended Full well | 16 |
| Readout Noise | 16 |
| Dark Current..... | 16 |
| QE Curve..... | 17 |
| Mechanical Drawing | 18 |
| BFL Solutions | 19 |
| Package List..... | 21 |
| Warranty & Shipping Policy | 22 |

Product Features

DSO cooled camera line is the most advanced product line in Player One history. We start the project from 2021, through a lot of modify and rebuild we made this final version. It brings our newest technology and design to everyone, we are very proud to introduce this camera line.



The image features a red and black Zeus camera against a starry space background. The camera is shown from a three-quarter perspective, highlighting its lens, body, and rear panel with various ports and controls. The text is arranged around the camera, listing its key technical specifications.

| Feature | Specification |
|------------------------|--------------------------------------|
| Full-Frame | 61 Mega Pixels |
| Sony IMX455 Mono/Color | Non-Amp-Glow Back-Illuminated Sensor |
| Rear 4P | Sensor Tilt Plate |
| 16bit | ADC bit depth |
| 512MB | DDR3 buffer |
| 6.5FPS | 9576 × 6388 |
| Anti Dew | Adjustable Dew Heater |
| 91%/80% | Mono/Color QE Peak |
| Delta-T | 35°C Deep Cooling |
| 1.27e | Readout Noise |
| Type-C | USB3.0 port |
| 71.6Ke | Full Well |
| BFL Solution | Complete Imaging Train Solutions |

Technical parameters

| | |
|---|--|
| Sensor | New SONY IMX455AQK-K full-frame CMOS (mono) |
| Diagonal | 43.3mm |
| Total Pixels | 61 Mega Pixels |
| Max Resolution | 9576×6388 |
| Pixel Size | 3.76μm |
| Chip Size | 36mm×24mm |
| | |
| Shutter | Rolling shutter |
| Exposure Range | 32μs-2000s |
| Readout Noise | 4.2-1.27e |
| Full Well | 71.6k e |
| QE Peak | ≈91% |
| ADC | 16 bit |
| Cooling System | High quality 2 stage TEC cooling Component |
| Cooler Power Consumption | 12V – 3A Max |
| Delta T | 35°C ± 2°C (below ambient) |
| Working Temperature and Humidity | Working Temperature: -10°C—60°C Working Relative Humidity: 0%—80% |
| Protective Window | D55*2MM High Quality AR Plus (Anti Reflection) Multi-Layer Coating |
| Data Port | Type-C USB3.0/USB2.0 |
| Adapter | M54X0.75, 2" |
| Back Focal Length | 17.5mm, 12.5mm(without sensor tilt plate) |
| Diameter | 90mm |
| Weight | 650g |
| Frame Rate | Under USB3.0 mode Resolution 10bit ADC 16bit ADC 9576×6388 6.5FPS 3.2FPS 3840×2160 47FPS 11FPS 1920×1080 105FPS 22FPS 800×600 184FPS 39FPS More resolution options could be setup in capture software! |

Product Description

New Cutting-edge Design

Polygon like regular hexagon is very Player One, the DSO cooled cameras we want to make it more beautiful and practical. After a lot of trying, we fix the final style, which uses a scientific and technological octagon to construct the main body line and 4 sides are cambered surface, supplemented by round chamfers to achieve both rigidity and flexibility. The front piece is round to avoid diffraction on RASA. The positive red, which is like a summer fire, is matched with the low-key and steady black, and the super-fine frosting process on the entire surface makes the camera look luxurious and cool, and keep Player One style.



ZEUS 455M Pro cooled camera is developed by Player One Astronomy, it's design for advanced DSO imaging. it adopts **Sony Industrial grade IMX455ALK-K full-frame format** monochrome sensor. The **3.76um pixel size** accommodates a well depth of 71.6Ke with a total of **61MP** (the resolution is 9576*6388), and the diagonal is **43.3mm**.

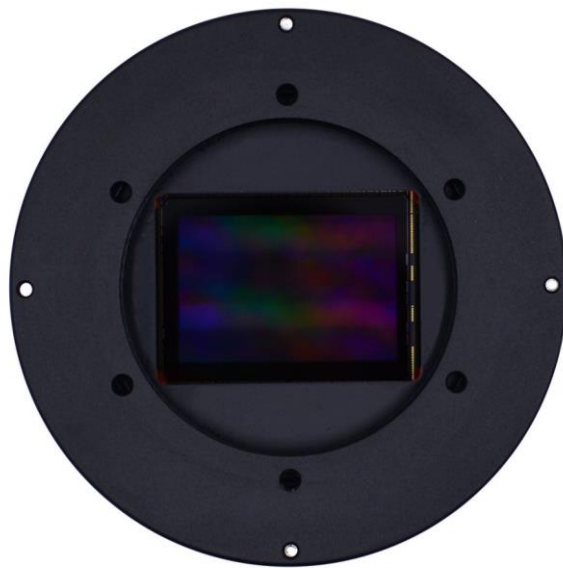

Rear Adjustment 4 Point Sensor Tilt Plate

When taking deepsky objects, using sensor tilt plate can get a much smaller field curvature of the telescope. We adopt rear Adjustment and 4 points tilt plate, it has a lot advantages in usage.



4 Point adjustment is easier to know which corner is needed to adjust. The built-in high-density sponge shading pad can block the light from the side slits without any side leakage.

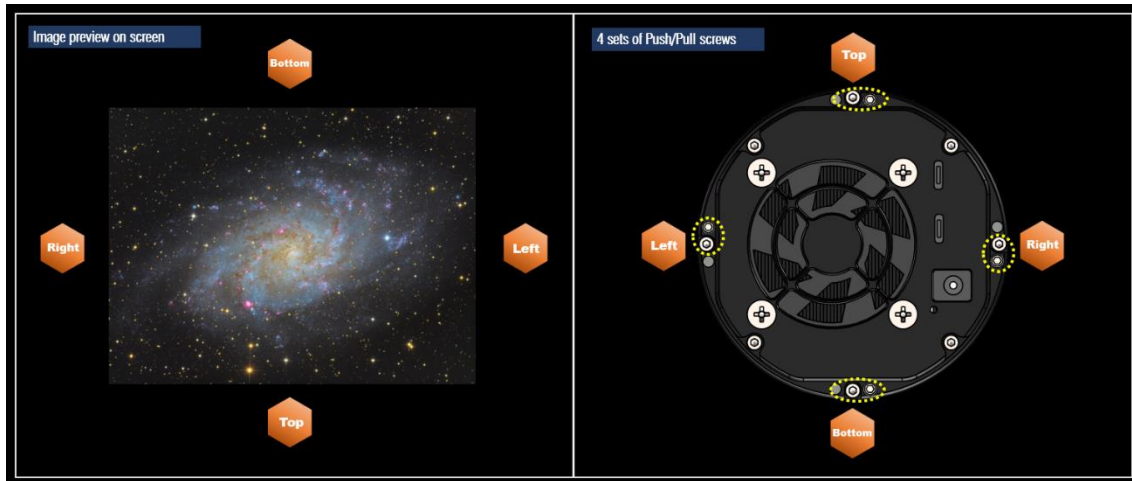

For understand 4 point adjustment method, we made a example for users:

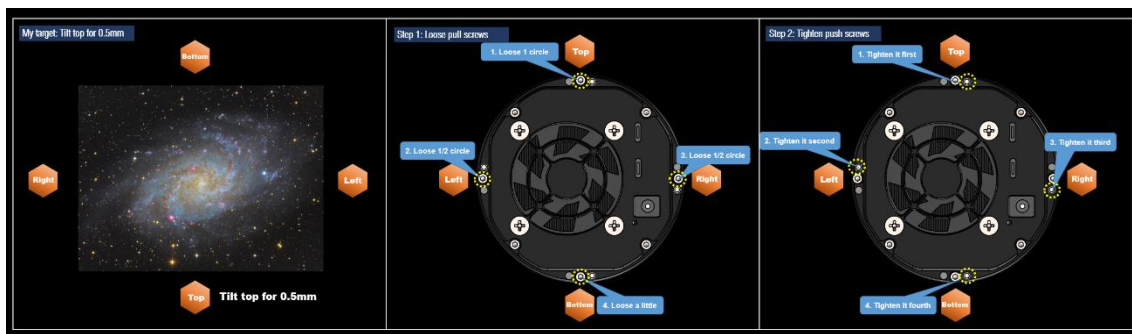

Deep Cooling

Player One cooled camera series use 2 Stage TEC Cooling unit, after improved the structure design to reject the heat back to camera chamber, Zeus Camera **Delta-T** can reach about **35°C**.

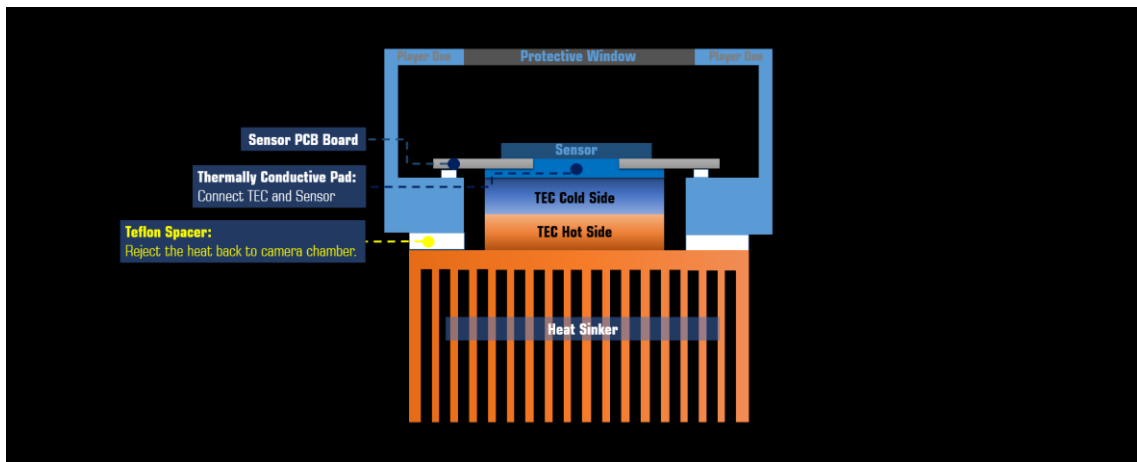

512MB DDR3 Cache

As an improvement, DDR3 cache in cooled cameras are increased to 512MB. It helps stabilize and secure data transmission, it effectively avoids frame dropping and greatly reduces readout noise.

With the DDR3 cache, the camera does not have high demands on computing needs any longer, it will still have excellent performance even if it is connected to a USB 2.0 port.

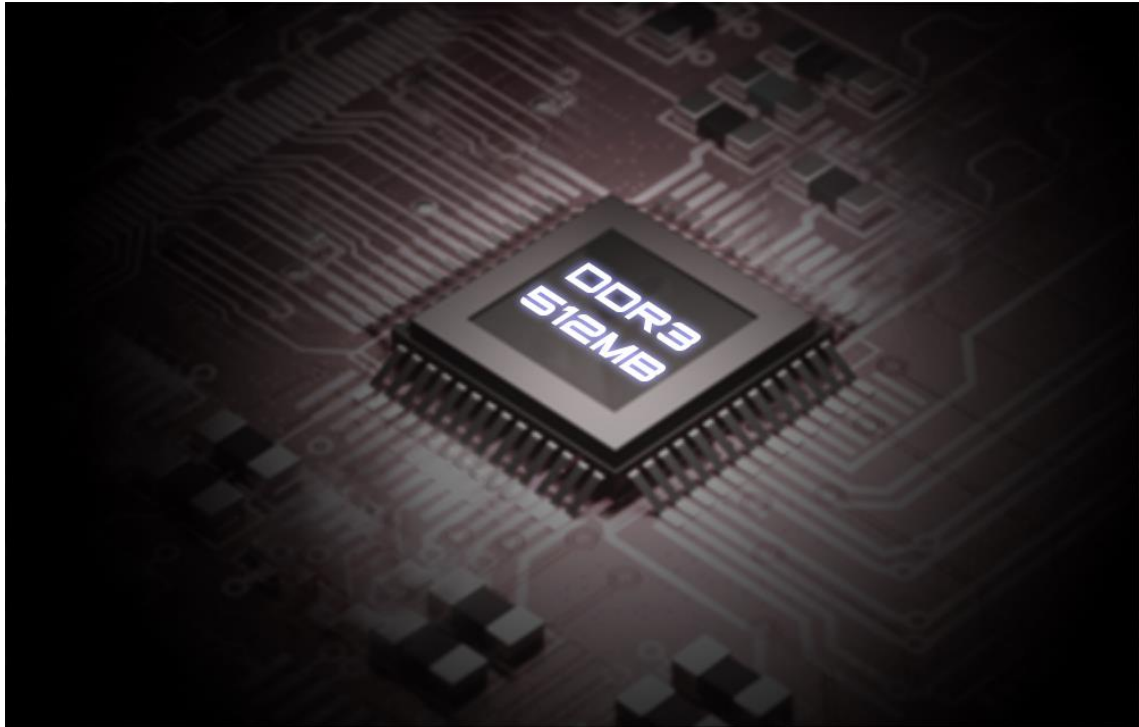

STARVIS Technology

ZEUS 455M Pro cooled camera based on **Sony STARVIS technology**, it is back-illuminated pixel technology used in CMOS image sensors.

Full-Frame Format

ZEUS 455M Pro cooled camera has full-frame format (36mm*24mm), it is very suitable for professional DSO imaging.

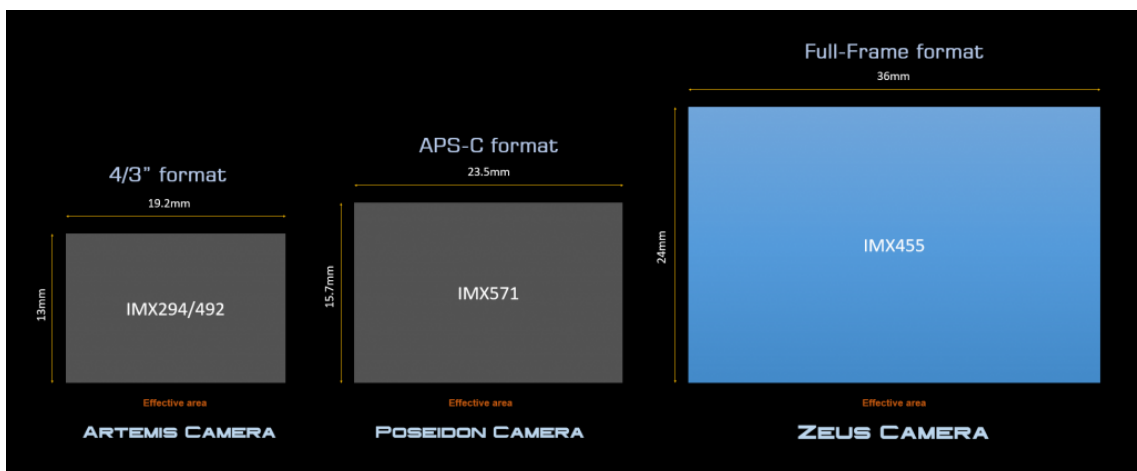

Native 16bit ADC

IMX455 has native 16-bit on-chip ADC. Native 16bit ADC (**65536 levels**) provide higher sample resolution than 12bit (4096 levels) or 14bit (16384 levels). When we do non-linear transformation, 16bit data can endure very strong transform and also could bring much better light and dark transition, furthermore 16bit can make the color more vivid.

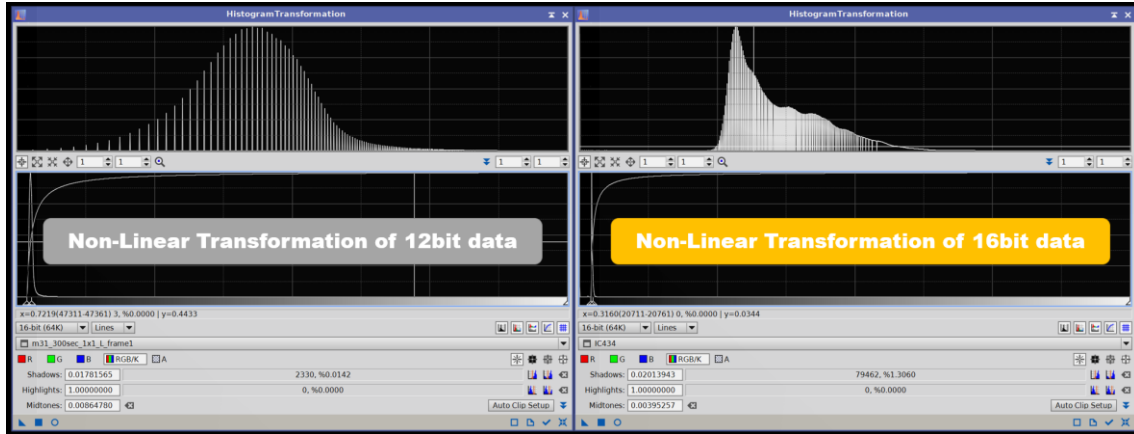

Non-Amp-Glow

ZEUS 455M Pro cooled camera is a Non-Amp-Glow camera too!

300s, gain=0, offset=5, dark frame at -5°C of ZEUS 455M Pro cooled camera:

[DOWNLOAD](#)

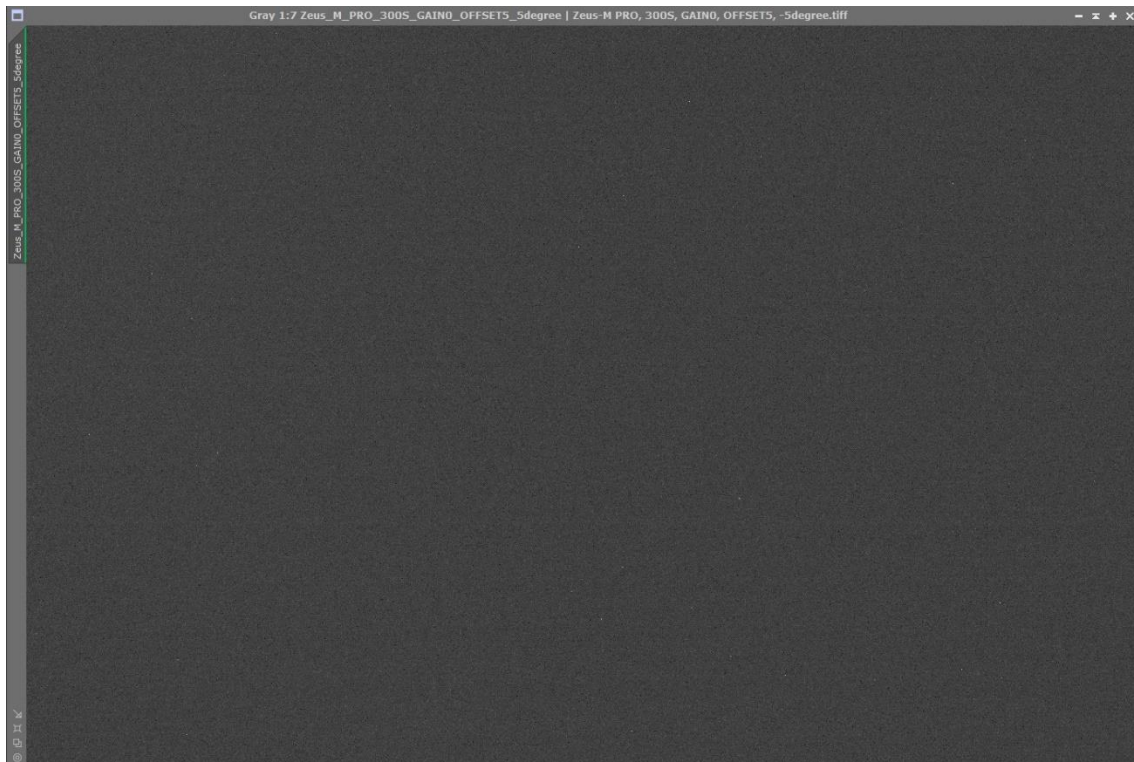

Preview of Dark frame: Exposure=300s, gain=0, offset=5, temp=-5°C STF auto-Stretch in Pixinsight 1.86

Non-Amp-Glow can give us very clean background, much easier to get high quality images.

Type-C Data port and Power port

Back piece of cooled camera has 2 Type-C data port and 12V DC 5.5×2.1mm power port.



Main data port support USB3.0 protocol, the camera can run 6.5fps under RAW8 mode. Type-C port is easier to plug in when assemble the imaging equipment in night.

When recording images, since the actual writing speed will be affected by the writing speed of the hard disk itself, when the hard disk writing speed is slow, the recording may not reach the theoretical speed. It is recommended that you use a high-quality solid state drive to record data to give full play to the performance of the camera.

The camera has 12V DC5.5*2.1mm port to provide enough power to TEC cooling system. If you don't need to power up cooling, only need to connect the main Type-C port, the camera will work as a uncooled camera.



Standard Cable Usage

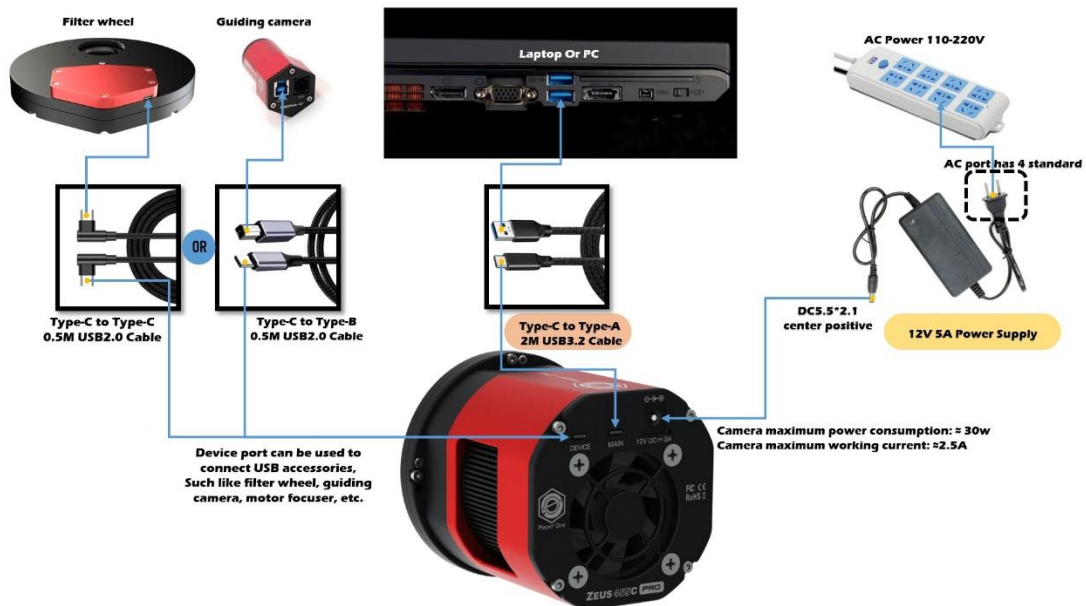

Cooling System and Anti-Dew Heater

In ASCOM window, we provide 3 adjustable parameters: Target temperature, Fan Speed and Anti-Dew power.

Standard Delta-T: 35°C (±2°C) , when ambient temp 30°C, fan speed 100%, dew heater 10%.

Recommend Delta-T settings: 30°C below ambient, fan speed 70%, dew heater 10%, power consumption 40- 60%.

The rotation speed of cooling fan is also adjustable; the default value is 70% speed.

Dew problem is the biggest enemy in astro imaging, the camera integrated anti-dew heater in front of the camera. The heat power is adjustable.

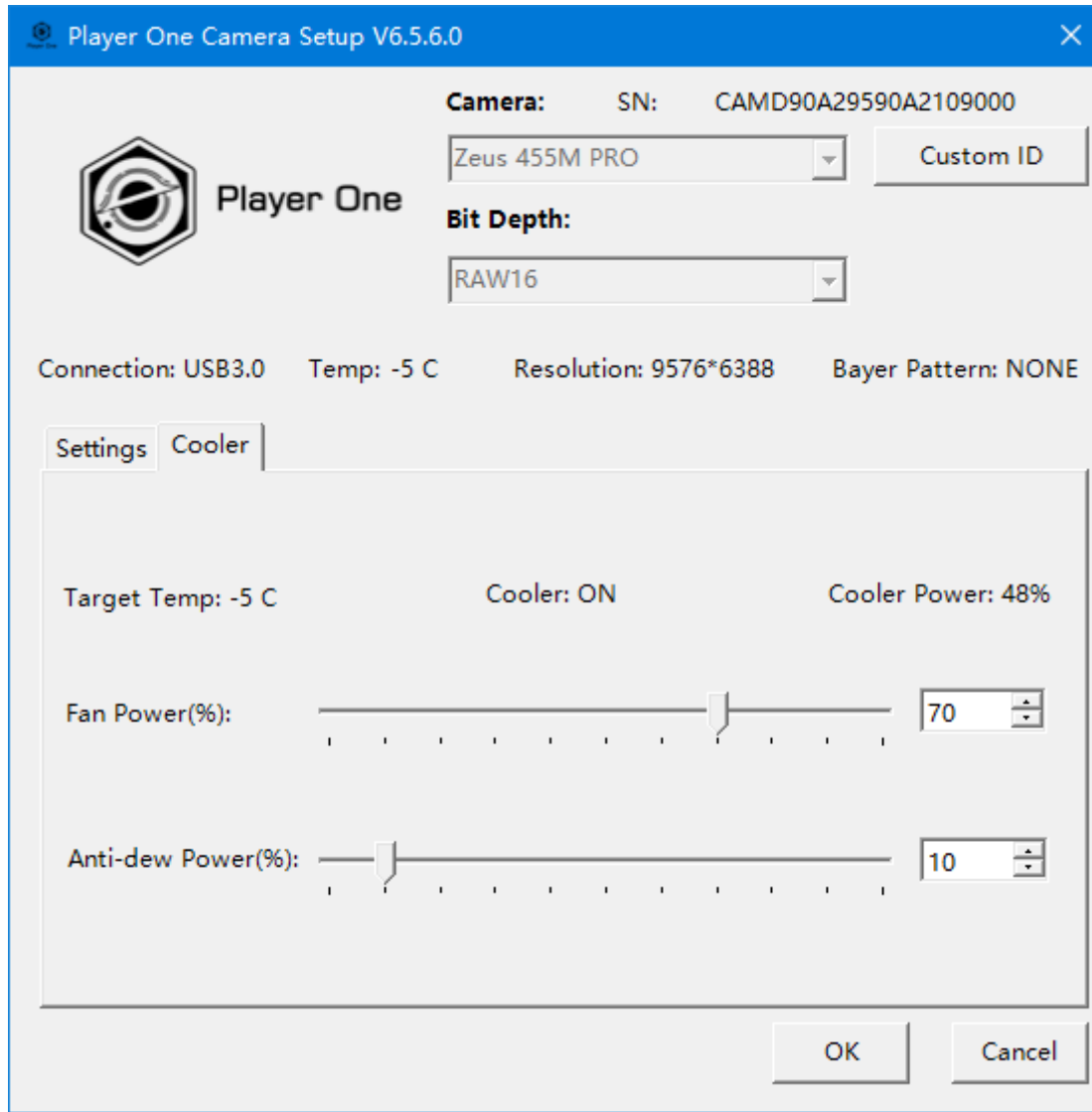

Overvoltage and overcurrent protection mechanism

Player One cameras produced by us ensures the safety of your camera and other equipment through overvoltage and overcurrent protection mechanisms.

Performance

Dual Sampling Mode

ZEUS series has dual sampling mode. **Normal** mode and **Low Noise** mode, they have different advantages in imaging.

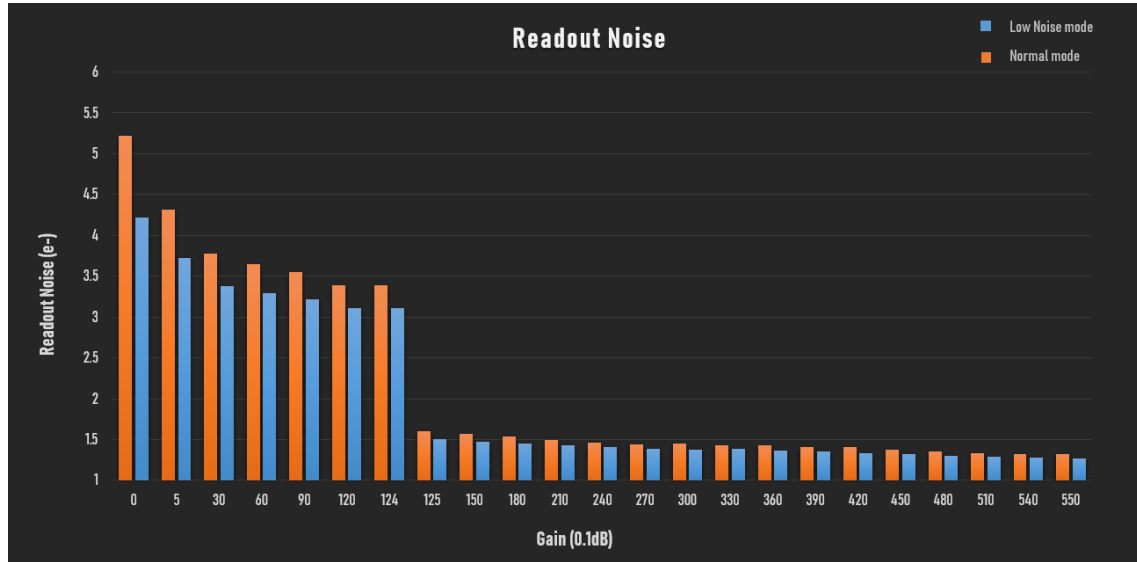

1. Normal mode has faster FPS, it is more suitable for **planetary imaging**.

2. Low Noise mode (LRN) mode has lower readout noise and higher dynamic range. it is more suitable for **DSO imaging**.

At gain=0, the camera has 14.2 stops dynamic range and 71.6Ke full well capacity, readout noise is 4.2e.

HCG open at gain=125, the camera has 13.5 stops dynamic range and 16.7Ke full well, readout noise drops to only 1.5e.

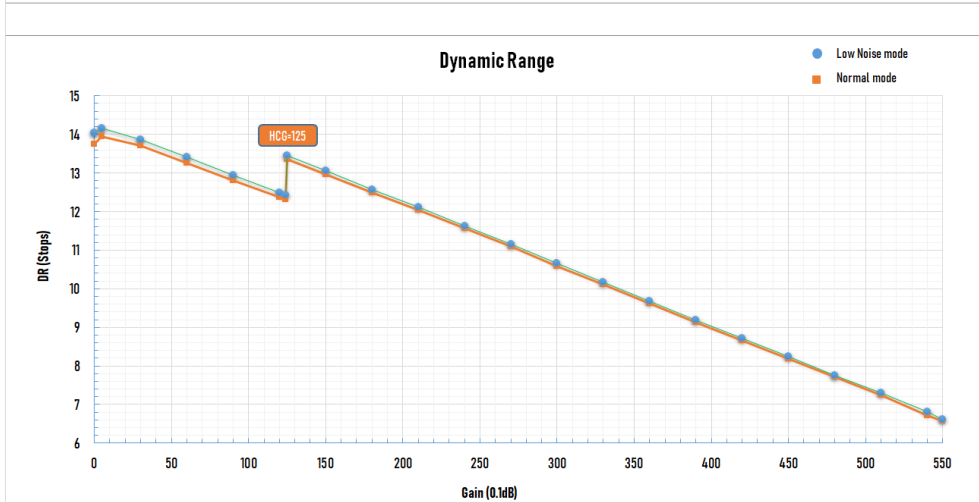
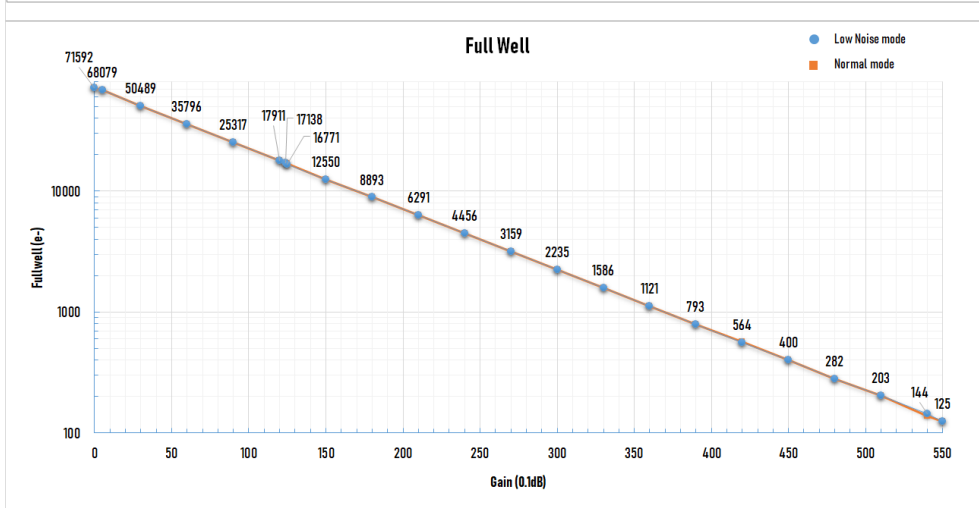
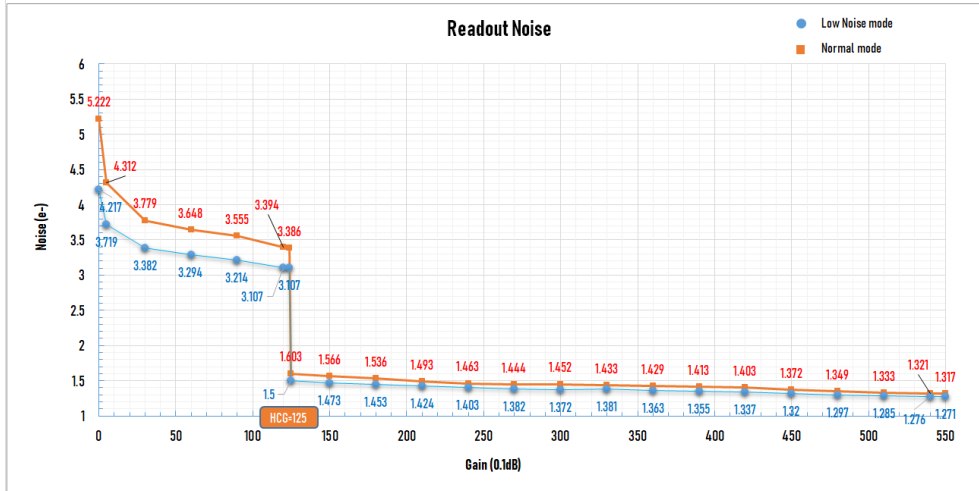
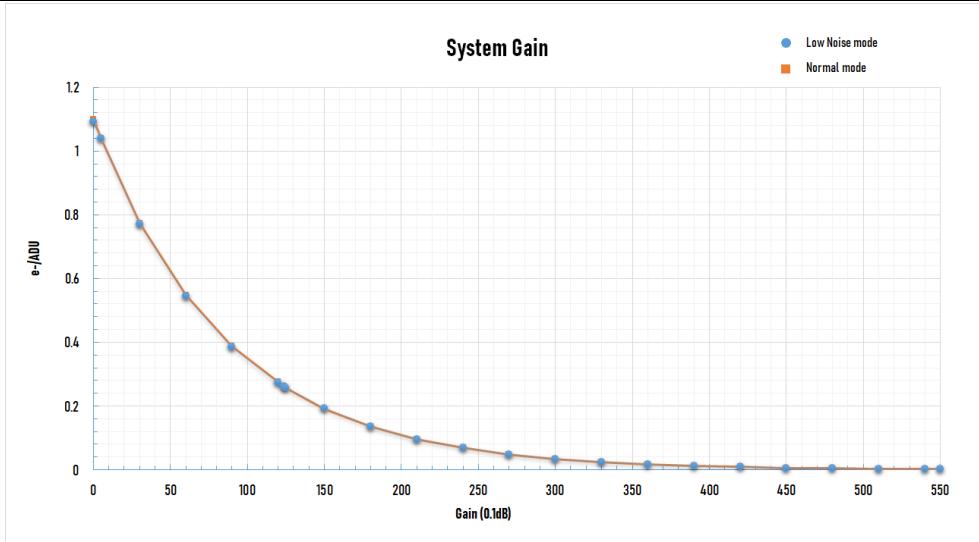

Frame rate

ZEUS 455M Pro cooled camera can run 6.5FPS under RAW8 mode, 3.2FPS under RAW16 mode.

Extended Full well

ZEUS 455M Pro cooled camera has 71.6Ke full well.

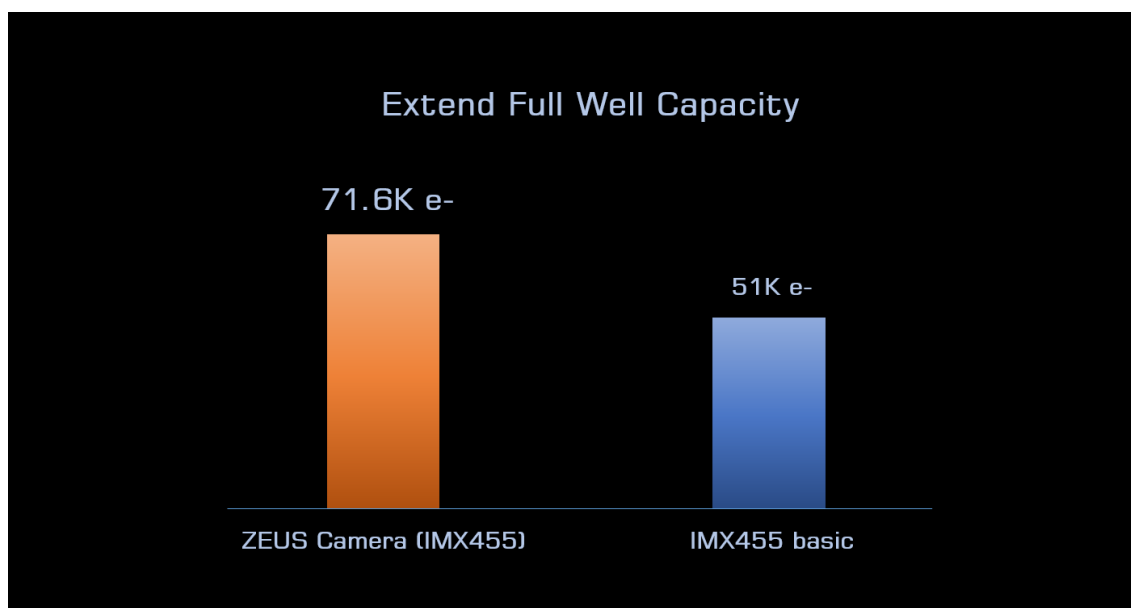

Readout Noise

Regarding readout noise, we solemnly promise that all values are obtained from actual tests. And for users, you could use Sharpcap 4 for testing. SC4 has a function called **Sensor Analysis**, provide a very simple way to test readout noise.

We wrote a tutorial on our website: <https://player-one-astronomy.com/service/manuals/>

If you are interested in readout noise testing, you may try it yourself, which is very simple.

Dark Current

The dark current is only 0.00014 e/s/pix at -20°C, and 0.00154e/s/pix at 0°C. In entire curve, dark current is almost like a straight a line, which can prove that ZEUS camera has very good quality.

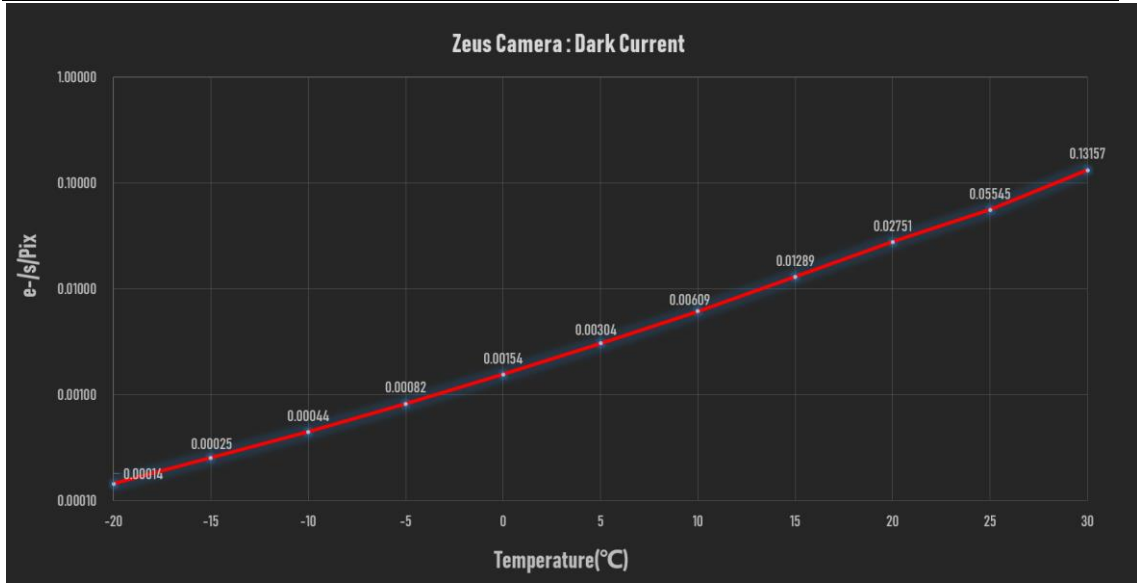

QE Curve

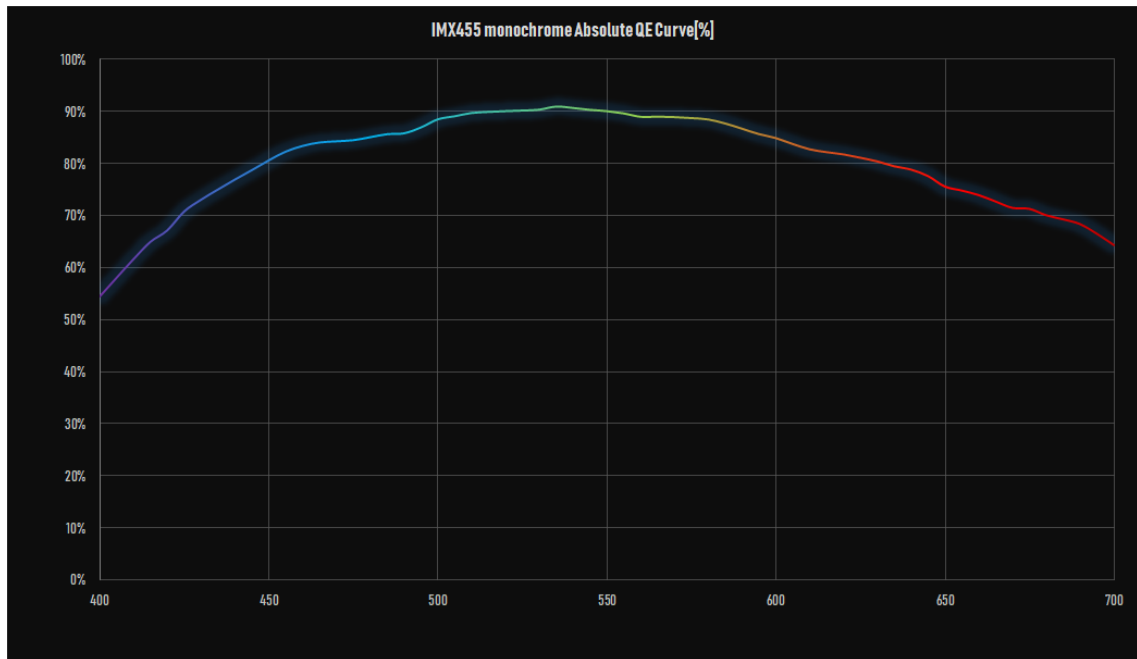

Mechanical Drawing

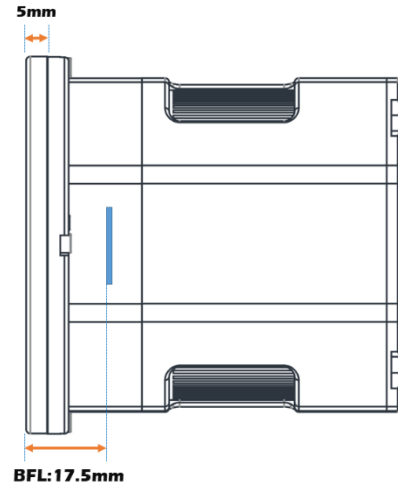
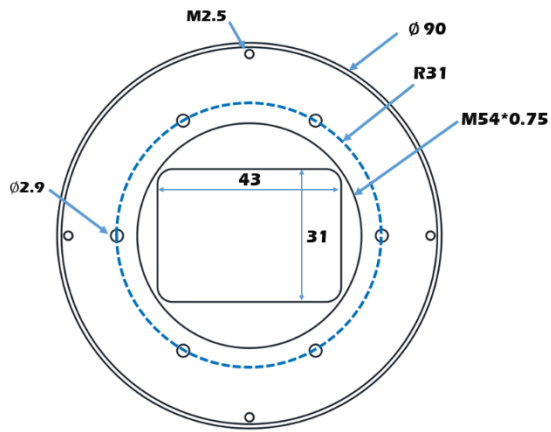

BFL Solutions

ZEUS 455M PRO camera + BASIC BFL solution

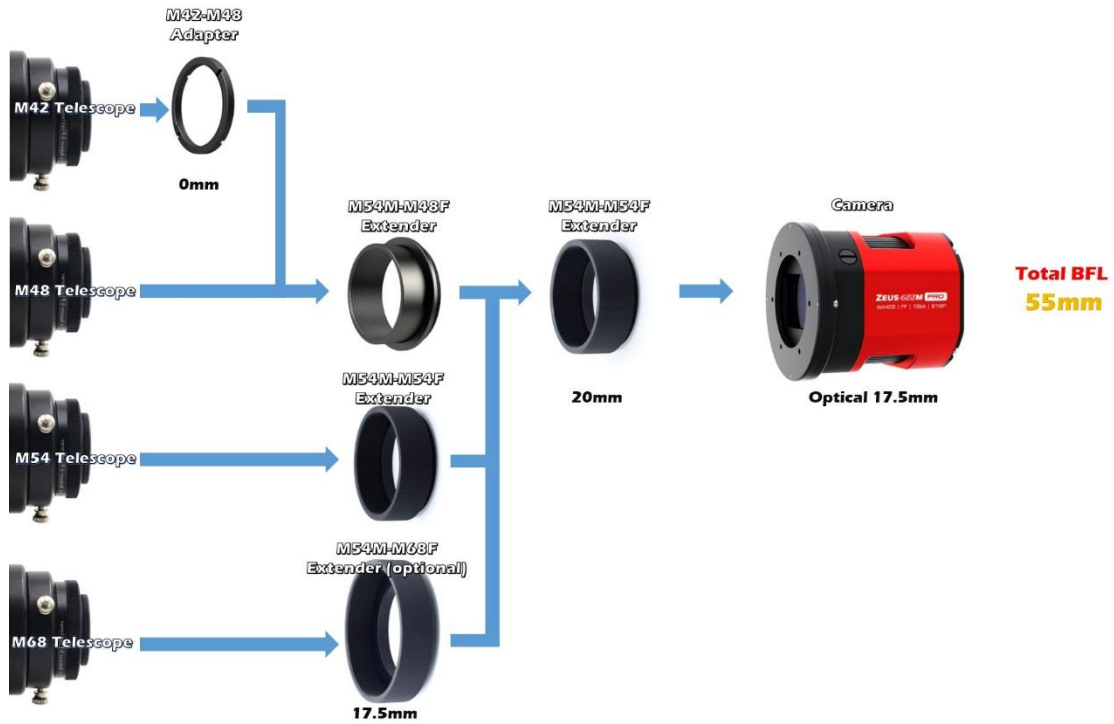

ZEUS 455M PRO camera + Phoenix Wheel 5X2"/7X2"/7X50mm BFL solution

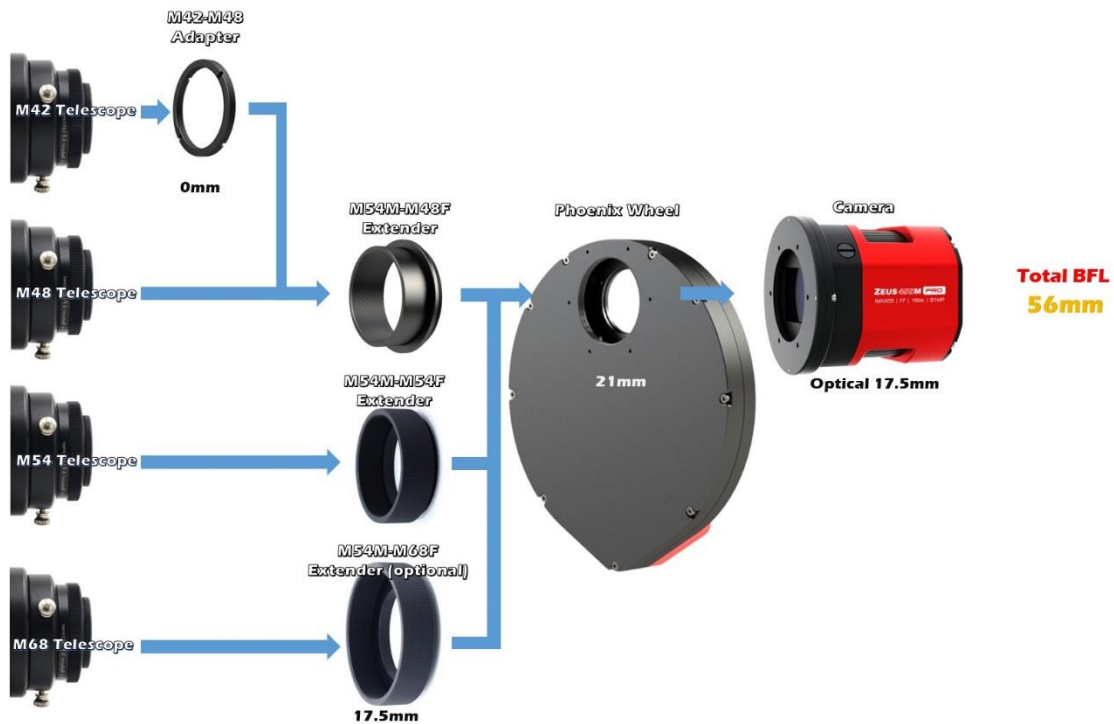

ZEUS 455M PRO camera + Phoenix Wheel 5X2"/7X2"/7X50mm + FHD-OAG MAX BFL solution













Notice: Some BFL solution is 56mm (Compensate light path differences which caused by filters)

Package List

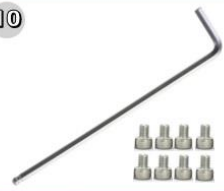

Camera package

| | | | |
|--|--|---|--|
| <p>1</p>  <p>Camera+ Metal Cover</p> | <p>2</p>  <p>M54M-M54F Extender 17.5mm</p> | <p>3</p>  <p>M54M-M54F Extender 20mm</p> | <p>4</p>  <p>M54M-M48F Adapter 17.5mm</p> |
| <p>5</p>  <p>M48M-M42F Adapter 0mm</p> | <p>6</p>  <p>Air Blower</p> | <p>7</p>  <p>Type-C to Type-A 2M USB3.2 Cable</p> | <p>8</p>  <p>Type-C to Type-C 0.5M USB2.0 Cable</p> |
| <p>9</p>  <p>Type-C to Type-B 0.5M USB2.0 Cable</p> | <p>10</p>  <p>M2 Hexagonal Wrench×1 A bag of M2.5*5</p> | <p>11</p>  <p>Cable Tie</p> | <p>12</p>  <p>Camera Bag</p> |

Warranty & Shipping Policy

Payment method

We provide *PayPal* and *PayPal checkout* on our website.

Shipping and Delivery

Shipping Fee:

- Amount \geq 299USD: free express shipping
- Amount $<$ 299USD: 29.9USD for express shipping

Shipping Services:

- We usually use DHL, UPS, FedEx, TNT for shipping.
- Make sure your email is correct, we maybe will contact with you through emails in case of emergency.

If customer wants to designate a shipping company or has special requirement, please send an email to support@player-one-astronomy.com and tell us your detailed requirement.

Shipping time:

- Usually 7-14 days.
- Tracking number will be updated in 3 days after paid.

For orders from areas where transportation is not easy, such as islands, town in mountainous regions, delivery time will be slightly longer.

Please send an email to support@player-one-astronomy.com immediately, if the following occurs:

- Shipping delayed or has some abnormal information.
- The packing is badly damaged on arrival, take pictures and do not sign.

Tax

- The price on our website without tax.
- Please note that buyers are liable to charge tax involved, such as Import tax, VAT, customs handling fee, etc.
- Those fees possibly will be collected at the time of delivery by courier.

For best experiences, we recommend customers to purchase our products form local dealers.

After-sales Service

Warranty Policy

2-year free warranty (time start from delivered) for Player One products. If the product has any issue, please send the image or video and description to support@player-one-astronomy.com for further check to confirm.

- Purchase from Player One official online store, we will provide warranty service directly.
- Purchase form dealer, we will provide warranty service through dealer.

Repair in warranty, customer only pay the shipping fee of shipping back the product to us or dealer, and no other extra fees.

Replacement Policy

You can request our Replacement Service:

- √ Within 30 calendar days of receiving the product if the product does not match the original description of the product in one or more significant respects.
- √ Within 30 calendar days of receiving the product if the product suffers performance failure.

Please contact our After-Sales team by email to support@player-one-astronomy.com within 30 calendar days of receiving the products. Player One shall be responsible for the two-way replacement freight for any products sent in for replacement due to performance faults.

Warranty and Replacement Policy Exceptions:

- × Warranty service time or replacement service time expired.
- × Legal proof-of-purchase, receipts, or invoices are not provided, or are reasonably believed to have been forged or tampered with.
- × A product sent to Player One for replacement does not include all original accessories, attachments and packaging, or contains items damaged by user error.
- × A product is found to have no defects after all appropriate tests are conducted by Player One.
- × Any fault or damage of the product is caused by unauthorized use or modification of the product, including exposure to moisture, entry of foreign bodies (water, oil, sand, etc.) or improper installation or operation.
- × Product labels or serial numbers show signs of tampering or alteration.
- × Damage is caused by uncontrollable external factors, including falling down, fires, floods, or lightning strikes, etc.
- × Proof of damage during transit issued by the carrier cannot be provided.
- × Other circumstances stated in this policy.

In those situations, repair the product might have extra cost, we will estimate cost and email customer to know the information before send product back.