



Player One

Uranus-C Camera Manual

V1.0

Dec, 2024

Table of Contents

Product Features	3
Technical parameters	4
Product Description	5
STARVIS 2 Technology	5
Format	5
Full well	6
Highlight	7
Non-Amp-Glow	7
Recommended accessories	8
Features	9
Cutting-edge Design	9
2nd Gen – Sensor Tilt Plate	10
Passive Cooling System	10
256M DDR3 Cache	11
DPS technology	11
Overvoltage and overcurrent protection mechanism	12
Data Port	12
Performance	13
Readout Noise	14
QE Curve	14
Mechanical Drawing	15
Package List	16
Warranty & Shipping Policy	17

Product Features

Uranus-C and Mars-C II is not only for planetary imaging, but also very powerful for EAA & Lucky imaging!



Technical parameters

Sensor	New SONY IMX585 1/1.2" CMOS (color)
Diagonal	12.85mm
Total Pixels	8.3 Mega Pixels
Max Resolution	3856×2180
Pixel Size	2.9μm
Chip Size	11.2mm×6.3mm
Frame Rate	47FPS (10bit)
Bayer Matrix	RGGB
Shutter	Rolling shutter
Exposure Range	32μs-2000s
Readout Noise	6.5-0.7e
QE Peak	≈91%
Full Well	47k e
ADC	12 bit
Data Port	USB3.0/USB2.0
Adapter	1.25" / M42X0.75
Back Focal Length	12.5mm
Protective Window	D32*2MM High Quality AR Plus (Anti Reflection) Multi-Layer Coating
Diameter	66mm
Weight	160g
Resolution and FPS	Under USB3.0 mode Resolution 10bit ADC 3856×2180 46FPS 3840×2160 47FPS 1920×1080 187FPS More resolution options could be setup in capture software!

Product Description

Uranus-C is (IMX585) camera developed by Player One Astronomy, which adopts the **newest Sony IMX585 1/1.2" format** color sensor. The **2.9um pixel size** accommodates a well depth of **47Ke** with a total of **8.3MP** (the resolution is 3856*2180), and the diagonal is **12.85mm**.



STARVIS 2 Technology

Uranus-C (IMX585) and Mars-C II (IMX662) based on **Sony newest STARVIS 2 technology**, it is back-illuminated pixel technology used in CMOS image sensors.

Format

Uranus-C (IMX585) has 1/1.2" format, this size is quite big for imaging.

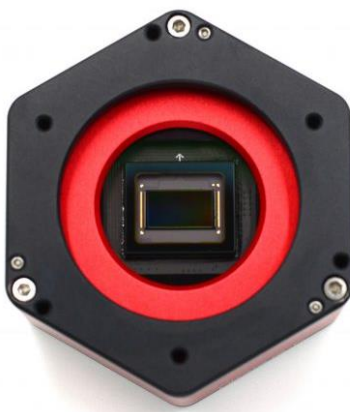

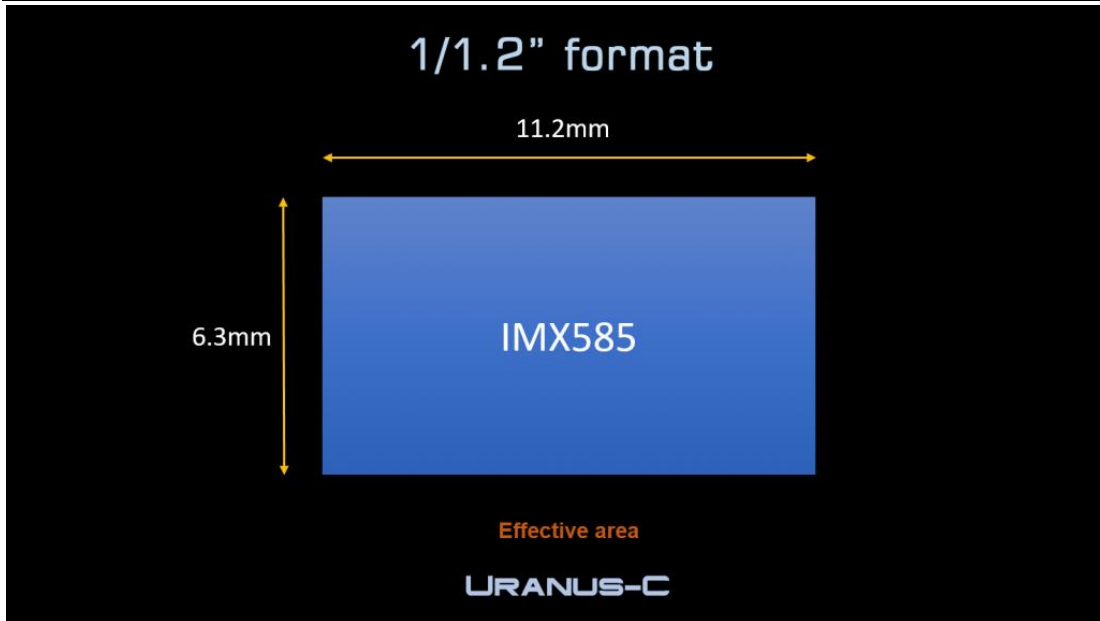

Full well

Uranus-C (IMX585) has 47Ke full well, it's almost 3.6 times than IMX485 (13Ke).

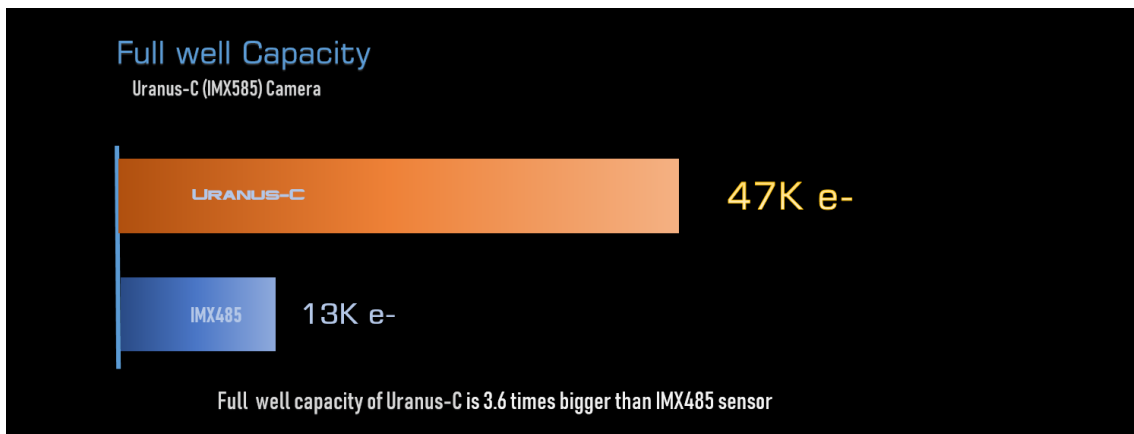

Highlight

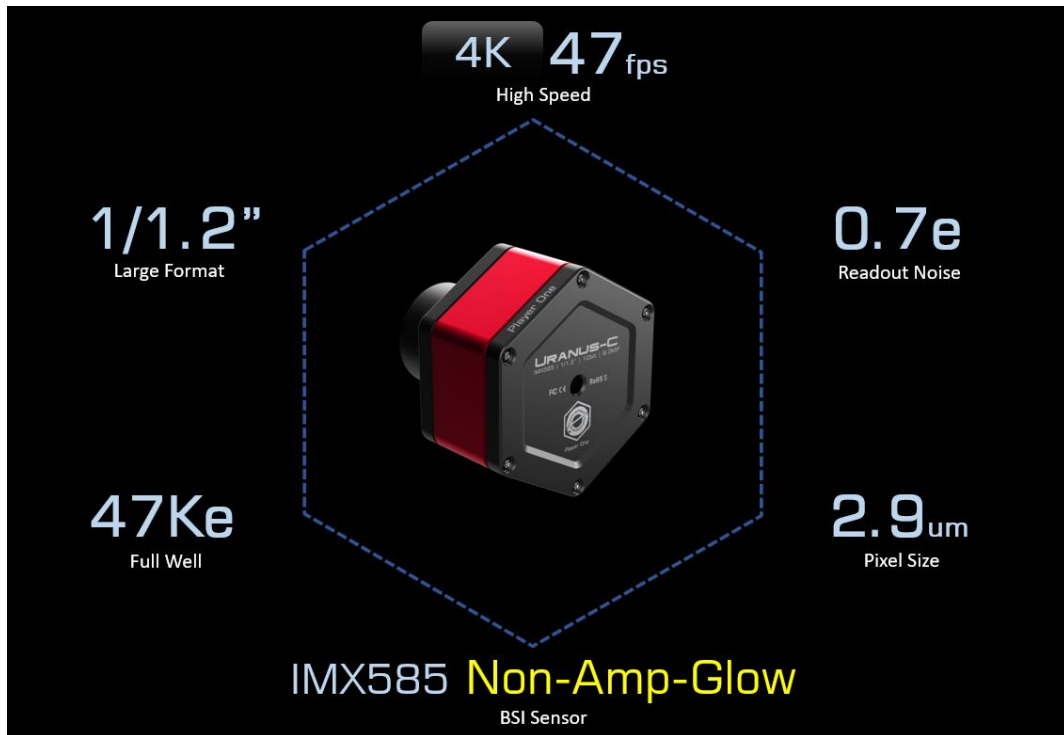

Non-Amp-Glow

Biggest surprise of Uranus-C (IMX585) camera is, its dark frame is totally “dark”, whatever we strength the curve, there is no AMP glow at all!
300s dark frame of Uranus-C camera (resize to 50%):

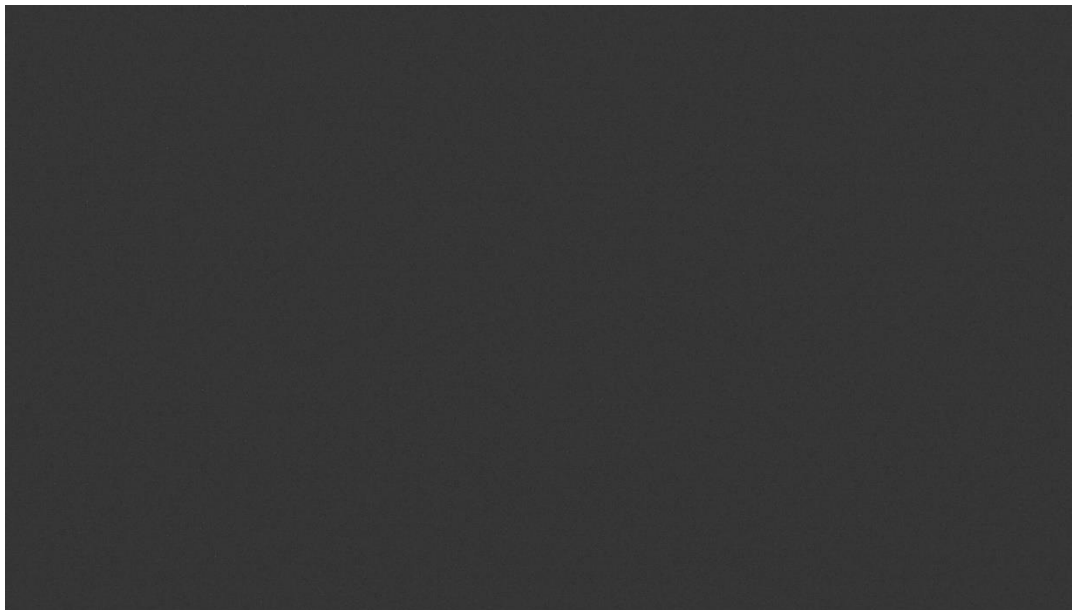

Non-Amp-Glow can give us very clean background, much easier to get high quality images.

Recommended accessories

ACS (Active Cooling System) is an external air-cooled system, designed for solar and big format planetary cameras which already has PCS (Passive Cooling System).

ACS can provide much better temperature control. When camera has PCS + ACS,

temperature is only 7°C higher than ambient, camera body is a little warm but won't hot!

ACS is not only can be used in daylight for solar imaging, it also could be used in night for DSO lucky imaging.

<https://player-one-astronomy.com/product/active-cooling-system-acs-for-uncooled-cameras/>



Features

The naming of Player One Astronomy cameras is unique. Planetary camera line, naming depend on the size of planets, Mars (1/3"), Neptune (1/2"), Uranus (1/1.2"), Saturn (1"), Jupiter (4/3").



4K@47fps **2K@105fps** **1080P@187fps**

Features:

- ✓ High Sensitivity | Newest Sony IMX585 color sensor.
- ✓ DDR Cache | DDR3 256MB.
- ✓ Passive Cooling System | Lower the sensor temperature.
- ✓ DPS Technology | Suppress dead pixels, improve image quality.
- ✓ Sensor Tilt Plate | Remove newton ring in solar imaging.
- ✓ USB3.0 | Up to 47FPS.
- ✓ ST4 Port | Easy for guiding.

URANUS-C
COLOR CAMERA

Uranus-C is best for EAA, Lunar and Planetary imaging.

Drivers and software download:

<http://player-one-astronomy.com/service/software/>

Manuals download:

<http://player-one-astronomy.com/service/manuals/>

Cutting-edge Design

The planetary cameras developed by Player One Astronomy uses a scientific and technological regular hexagon to construct the main body line, supplemented by round chamfers to achieve both rigidity and flexibility. The positive red, which is like a summer fire, is matched with the low-key and steady black, and the super-fine frosting process on the entire surface makes the camera look luxurious and cool, highlighting the style of high-end players, can't take my eyes off.



2nd Gen – Sensor Tilt Plate

When taking deepsky objects, using sensor tilt plate can get a much smaller field curvature of the telescope.

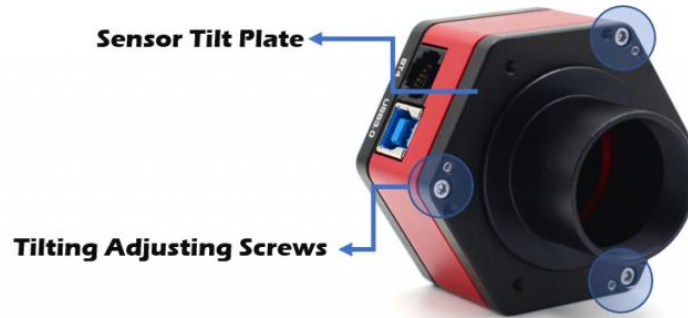

The built-in high-density sponge shading pad can block the light from the side slits without any side leakage.

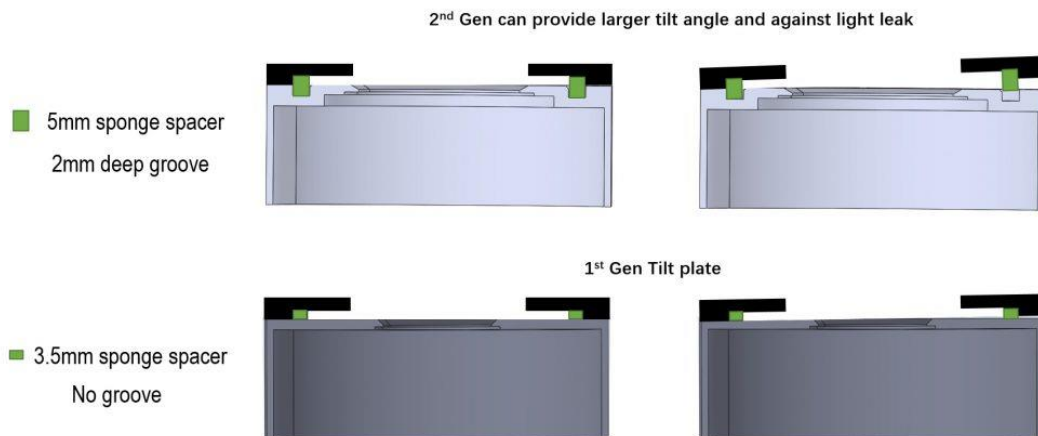

Passive Cooling System

Player One add a new feature called Passive Cooling System to conduct the heat from the sensor out.

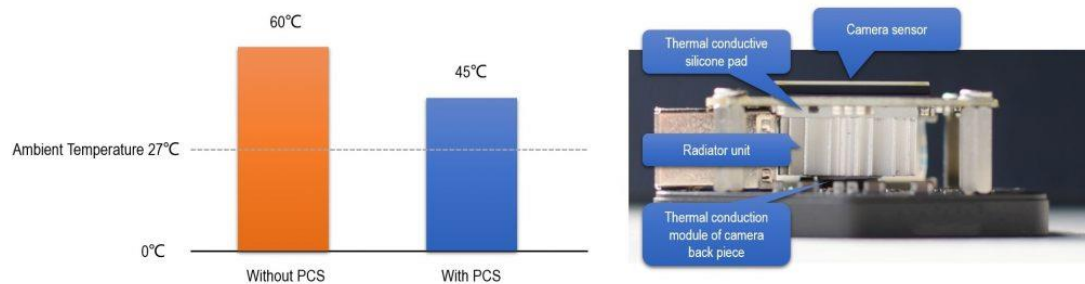

256M DDR3 Cache

Player One Astronomy cameras are the first one who adopts the DDR3 cache in all planetary cameras in the world! It helps stabilize and secure data transmission, it effectively avoids frame dropping and greatly reduces readout noise.

With the DDR3 cache, the camera does not have high demands on computing needs any longer, it will still have excellent performance even if it is connected to a USB 2.0 port.

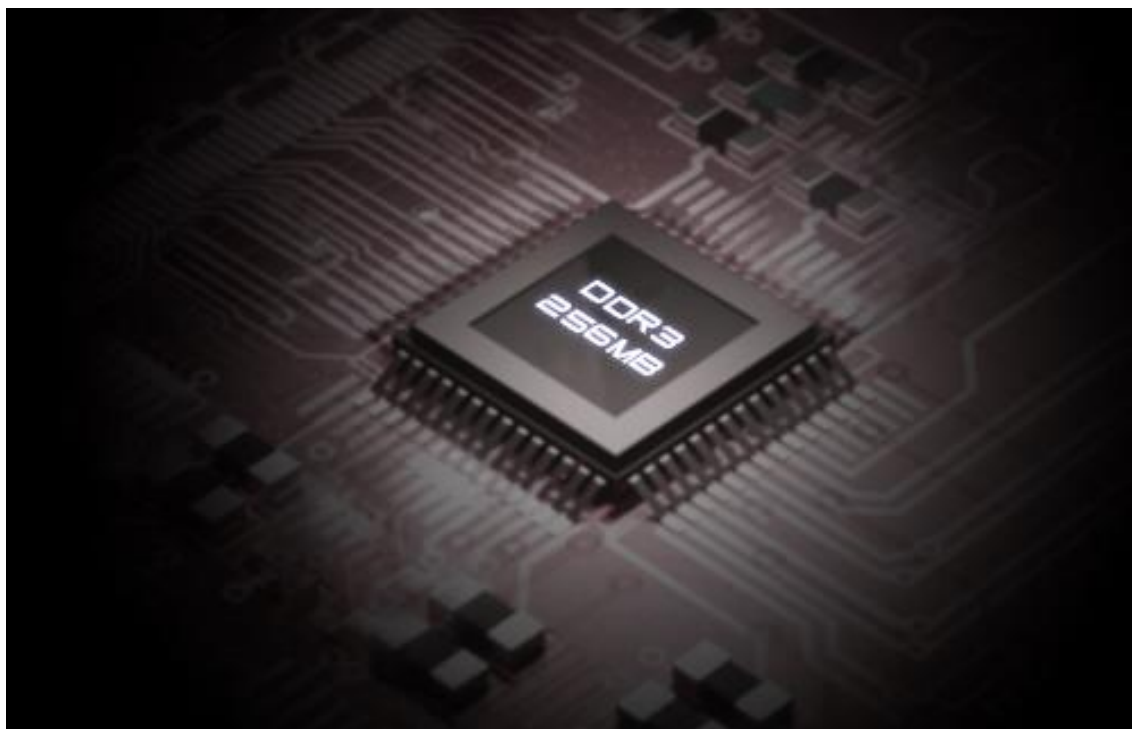

DPS technology

The planetary cameras from Player One Astronomy have DPS (Dead Pixel Suppression) technology. The DPS is analyses many dark frames to find out those fixed abnormal pixel and record the map in camera memory. In imaging, each exposure frames, those position of dead pixels will be given a median value according to the active pixels around that abnormal pixel.

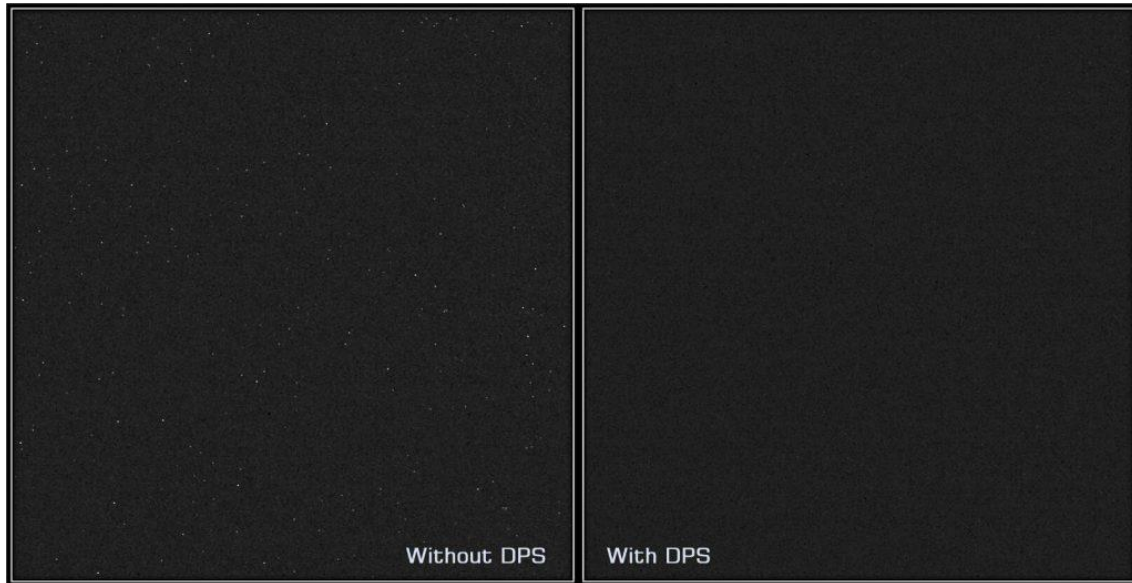

Overvoltage and overcurrent protection mechanism

Player One cameras produced by us ensures the safety of your camera and other equipment through overvoltage and overcurrent protection mechanisms.

Data Port

When the camera is connected to the USB3.0 interface and full-resolution preview is used, it can reach 47 FPS in RAW8 mode (10bit ADC). When recording images, since the actual writing speed will be affected by the writing speed of the hard disk itself, when the hard disk writing speed is slow, the recording may not reach the theoretical speed. It is recommended that you use a high-quality solid state drive to record data to give full play to the performance of the camera.

Use the ST4 guide cable to connect the camera and the AUTO GUIDE port of the equatorial mount to do guiding.

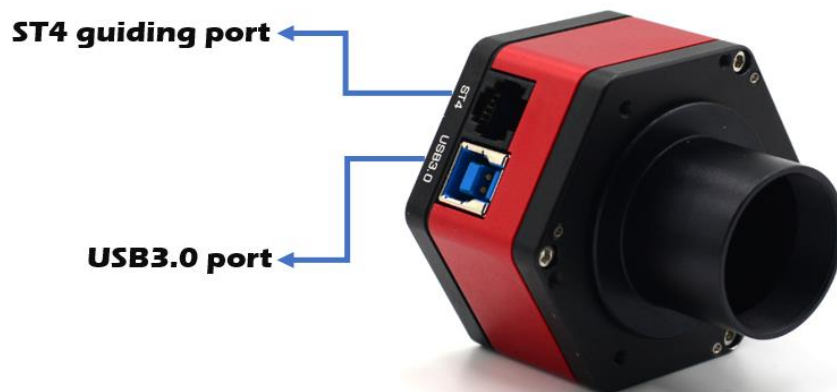

Performance

HCG open at gain=210.

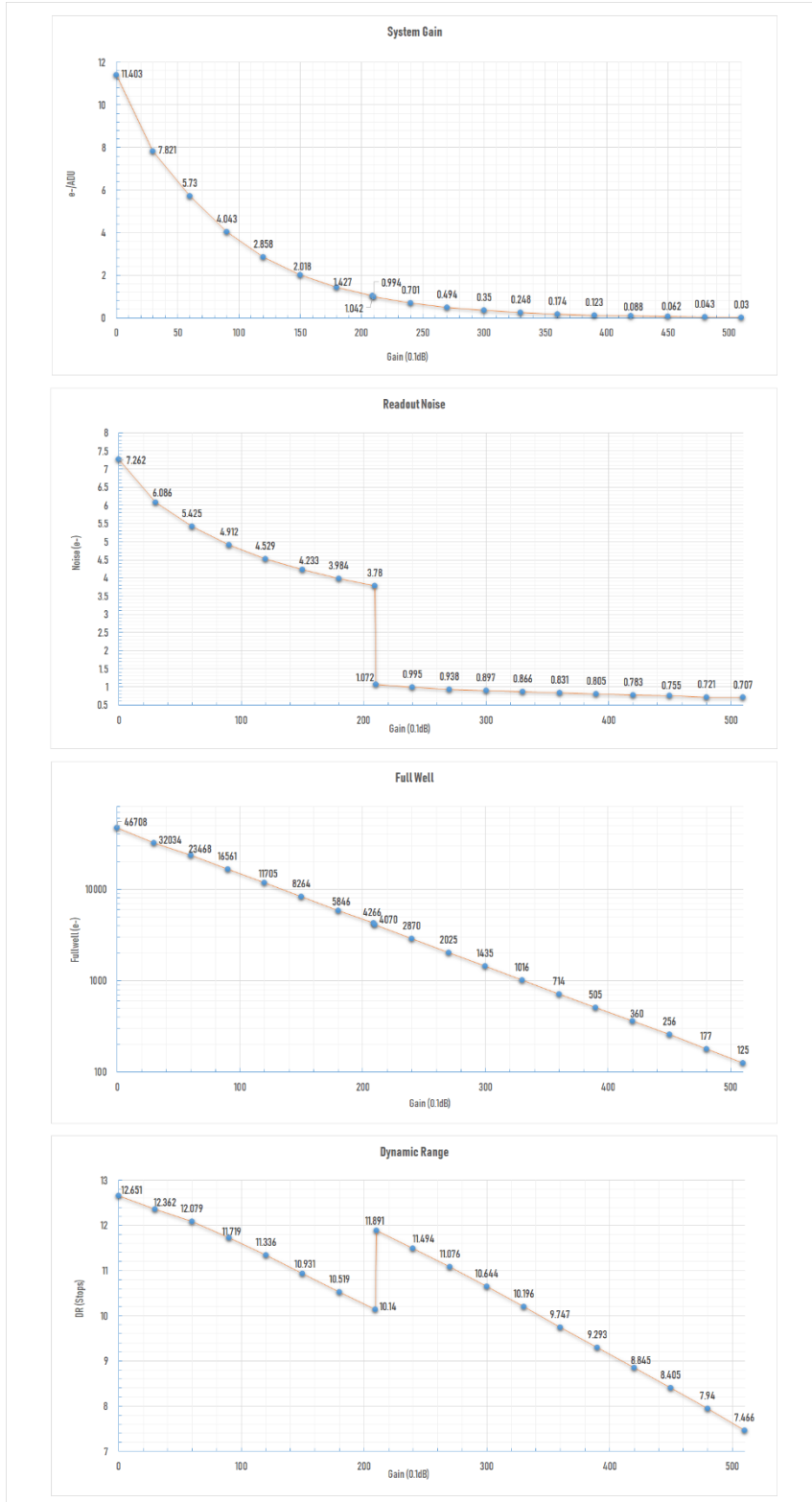

Readout Noise

Regarding readout noise, we solemnly promise that all values are obtained from actual tests. And for users, you could use Sharpcap 4 for testing. SC4 has a function called **Sensor Analysis**, provide a very simple way to test readout noise.

We wrote a tutorial on our website:

<https://player-one-astronomy.com/service/manuals/>

If you are interested in readout noise testing, you may try it yourself, which is very simple.

QE Curve

This relative QE curve is provided by SONY Co., Ltd. This data is authentic and authoritative!

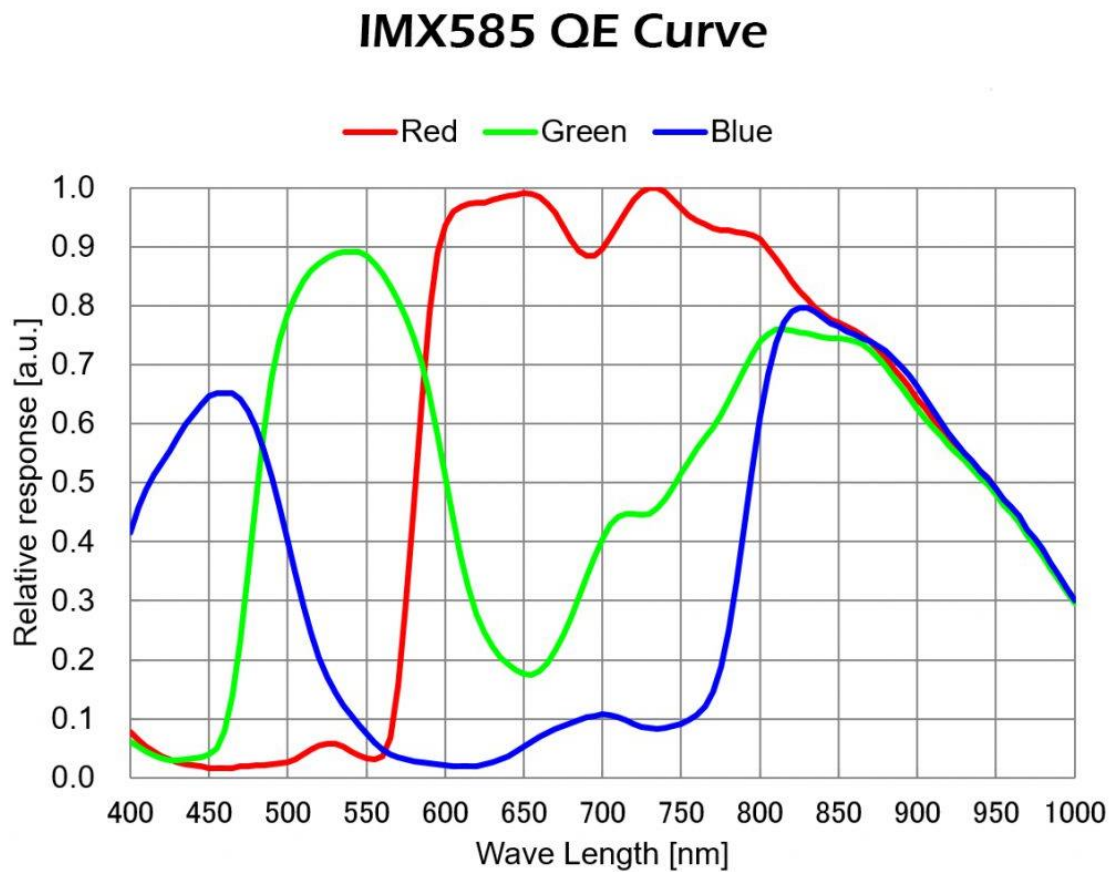

Mechanical Drawing

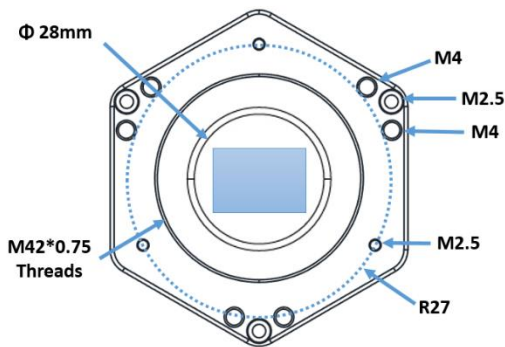
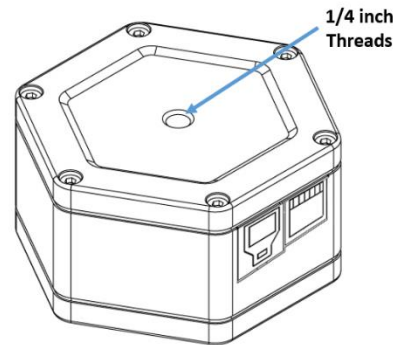
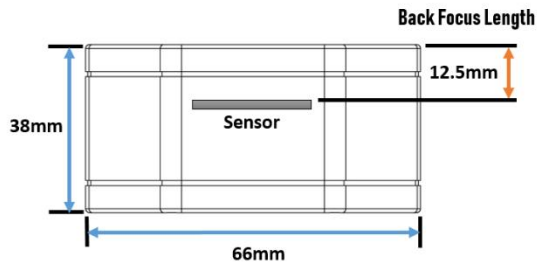

Package List



Camera Package

<p>1</p> 	<p>2</p> 	<p>3</p> 
<p>Camera and T-mount</p>	<p>USB3.0 Cable</p>	<p>ST4 Cable</p>
<p>4</p> 	<p>5</p> 	<p>6</p> 
<p>M2 Hexagonal wrench</p>	<p>1.25" Cover</p>	<p>Air Blower</p>

Warranty & Shipping Policy

Payment method

We provide *PayPal* and *PayPal checkout* on our website.

Shipping and Delivery

Shipping Fee:

- Amount \geq 299USD: free express shipping
- Amount $<$ 299USD: 29.9USD for express shipping

Shipping Services:

- We usually use DHL, UPS, FedEx, TNT for shipping.
- Make sure your email is correct, we maybe will contact with you through emails in case of emergency.

If customer wants to designate a shipping company or has special requirement, please send an email to support@player-one-astronomy.com and tell us your detailed requirement.

Shipping time:

- Usually 7-14 days.
- Tracking number will be updated in 3 days after paid.

For orders from areas where transportation is not easy, such as islands, town in mountainous regions, delivery time will be slightly longer.

Please send an email to support@player-one-astronomy.com immediately, if the following occurs:

- Shipping delayed or has some abnormal information.
- The packing is badly damaged on arrival, take pictures and do not sign.

Tax

- The price on our website without tax.
- Please note that buyers are liable to charge tax involved, such as Import tax, VAT, customs handling fee, etc.
- Those fees possibly will be collected at the time of delivery by courier.

For best experiences, we recommend customers to purchase our products form local dealers.

After-sales Service

Warranty Policy

2-year free warranty (time start from delivered) for Player One products. If the product has any issue, please send the image or video and description to support@player-one-astronomy.com for further check to confirm.

- Purchase from Player One official online store, we will provide warranty service directly.
- Purchase form dealer, we will provide warranty service through dealer.

Repair in warranty, customer only pay the shipping fee of shipping back the product to us or dealer, and no other extra fees.

Replacement Policy

You can request our Replacement Service:

- √ Within 30 calendar days of receiving the product if the product does not match the original description of the product in one or more significant respects.
- √ Within 30 calendar days of receiving the product if the product suffers performance failure.

Please contact our After-Sales team by email to support@player-one-astronomy.com within 30 calendar days of receiving the products. Player One shall be responsible for the two-way replacement freight for any products sent in for replacement due to performance faults.

Warranty and Replacement Policy Exceptions:

- × Warranty service time or replacement service time expired.
- × Legal proof-of-purchase, receipts, or invoices are not provided, or are reasonably believed to have been forged or tampered with.
- × A product sent to Player One for replacement does not include all original accessories, attachments and packaging, or contains items damaged by user error.
- × A product is found to have no defects after all appropriate tests are conducted by Player One.
- × Any fault or damage of the product is caused by unauthorized use or modification of the product, including exposure to moisture, entry of foreign bodies (water, oil, sand, etc.) or improper installation or operation.
- × Product labels or serial numbers show signs of tampering or alteration.
- × Damage is caused by uncontrollable external factors, including falling down, fires, floods, or lightning strikes, etc.
- × Proof of damage during transit issued by the carrier cannot be provided.
- × Other circumstances stated in this policy.

In those situations, repair the product might have extra cost, we will estimate cost and email customer to know the information before send product back.