



Player One

# Apollo-M MINI Camera Manual

V1.0

Dec, 2024

## Table of Contents

Product Features.....	3
Technical parameters .....	4
Product Description .....	5
Pregius Technology .....	5
Format.....	5
Pixel size.....	6
HCG mode.....	6
Recommended accessories.....	7
ACS (Active Cooling System).....	7
Features .....	8
Cutting-edge Design.....	8
2nd Gen – Sensor Tilt Plate.....	9
Passive Cooling System.....	10
256M DDR3 Cache .....	10
DPS technology.....	11
Overvoltage and overcurrent protection mechanism .....	11
Data Port.....	11
Performance.....	12
Readout Noise .....	13
QE Curve .....	13
HCG Mode.....	13
Mechanical Drawing.....	14
Package List.....	15
Warranty & Shipping Policy.....	16

## Product Features

Apollo series is the world's first camera line designed specifically for solar photography, named after Apollo.

The Apollo series features Sony sensors with global shutters and a focus on monochrome sensors.

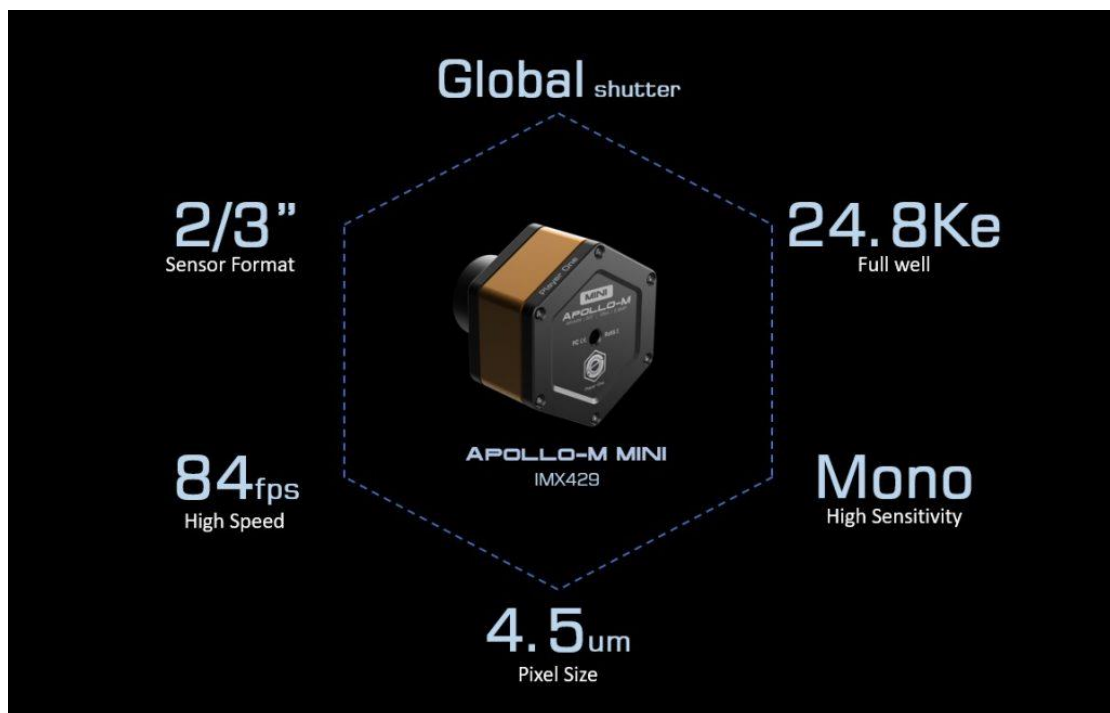

## Technical parameters

<b>Sensor</b>	SONY IMX429 2/3" CMOS (mono)
<b>Diagonal</b>	11mm
<b>Total Pixels</b>	2.8 Mega Pixels
<b>Max Resolution</b>	1944x1472
<b>Pixel Size</b>	4.5 $\mu$ m
<b>Chip Size</b>	8.75mmx6.6mm
<b>Frame Rate</b>	84FPS (12bit)
<b>Shutter</b>	Global shutter
<b>Exposure Range</b>	32 $\mu$ s-2000s
<b>Readout Noise</b>	5.6-1.45e
<b>QE Peak</b>	$\approx$ 79%
<b>Full Well</b>	25k e
<b>ADC</b>	12 bit
<b>Data Port</b>	USB3.0/USB2.0
<b>Adapter</b>	1.25" / M42X0.75
<b>Back Focal Length</b>	12.5mm
<b>Protective Window</b>	D32*2MM High Quality AR Plus (Anti Reflection) Multi-Layer Coating
<b>Diameter</b>	66mm
<b>Weight</b>	160g
<b>Resolution and FPS</b>	Under USB3.0 mode Resolution 12bit ADC 1944x1472 84FPS More resolution options could be setup in capture software!

## Product Description

Apollo-M MINI is a solar camera developed by Player One Astronomy, which adopts the Sony IMX429 **2/3" format** monochrome sensor. The **4.5um pixel size** accommodates a well depth of **24.8Ke** with a total of **2.8MP** (the resolution is 1944\*1472), and the diagonal is **11mm**.

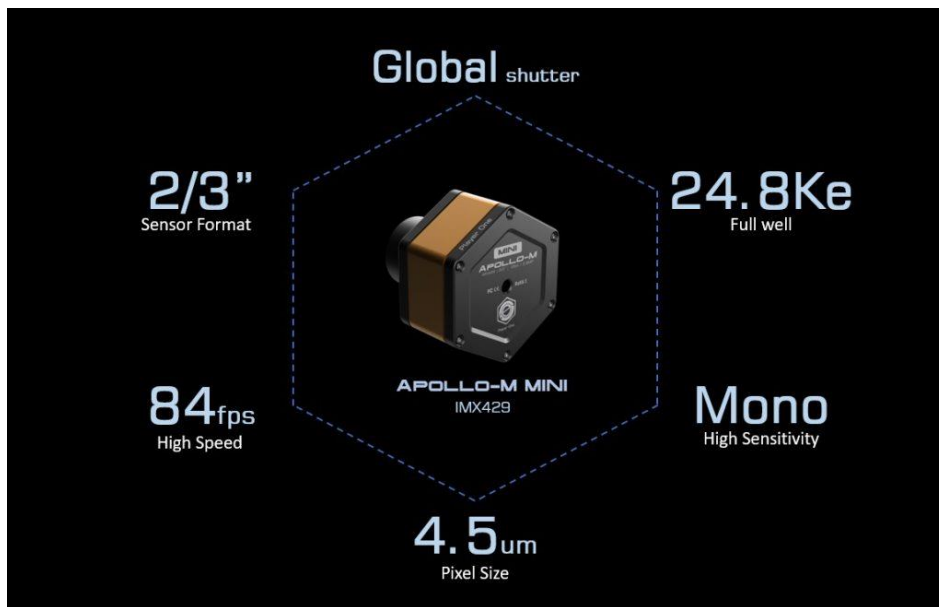

### Pregius Technology

Apollo-M MINI (IMX429) is based on **Pregius 3rd Generation**. According to the introduction of technical documents, pixel size of 3rd Gen usually is 4.5um, and full well is 25Ke.

### Format

Apollo-M MINI (IMX429) has 2/3" format, this size is between IMX178 and IMX174.



## Pixel size

4.5um pixel size is smaller than IMX174 camera, which means it can works provide higher resolution in same focal length.

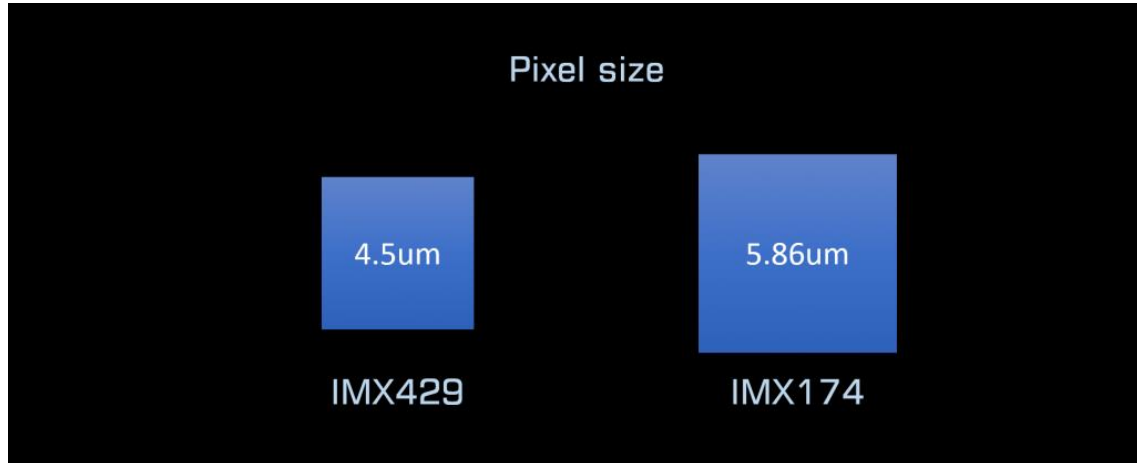

## HCG mode

Apollo-M MINI has HCG mode, when Gain>71 HCG will open automatically.

## Recommended accessories

### ACS (Active Cooling System)

ACS is an external air-cooled system, designed for solar and big format planetary cameras which already has PCS (Passive Cooling System). ACS can provide much better temperature control. When camera has PCS + ACS, temperature is only 7°C higher than ambient, camera body is a little warm but won't hot! ACS is not only can be used in daylight for solar imaging, it also could be used in night for DSO lucky imaging.

<https://player-one-astronomy.com/product/active-cooling-system-ac-s-for-uncooled-cameras/>



## Features

The naming of Player One Astronomy cameras is unique. Solar camera line, named after Apollo, the god of the sun. The suffix of the name describes the camera's biggest feature.



**1944×1472@84fps**    **1080P@100fps**

**Features:**

- ✓ High Sensitivity | Well-known Sony IMX429 Monochrome sensor.
- ✓ Global Shutter | Best for solar and artificial object imaging.
- ✓ DDR Cache | DDR3 256MB.
- ✓ Passive Cooling System | Lower the sensor temperature.
- ✓ DPS Technology | Suppress dead pixels, improve image quality.
- ✓ Sensor Tilt Plate | Remove newton ring in solar imaging.
- ✓ USB3.0 | Up to 84FPS.
- ✓ ST4 Port | Easy for guiding.

**APOLLO-M MINI**  
MONO CAMERA

Apollo-M MINI has 2/3" format sensor and 4.5um pixel size, best for capture details of Sun surface and space station.

Drivers and software download:

<http://player-one-astronomy.com/service/software/>

Manuals download:

<http://player-one-astronomy.com/service/manuals/>

## Cutting-edge Design

The planetary cameras developed by Player One Astronomy uses a scientific and technological regular hexagon to construct the main body line, supplemented by round chamfers to achieve both rigidity and flexibility. The positive orange, which is imply solar, is matched with the low-key and steady black, and the super-fine frosting process on the entire surface makes the camera look luxurious and cool, highlighting the style of high-end players, can't take my eyes off





## 2nd Gen – Sensor Tilt Plate

When taking solar photograph with prominence telescope, the Newton ring is annoying. Smoother solar image without Newton ring could be taken by adjusting the focal plate. Get a much smaller field curvature of the telescope.

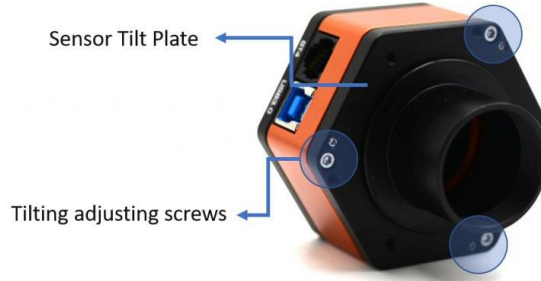

The built-in high-density sponge shading pad can block the light from the side slits without any side leakage.

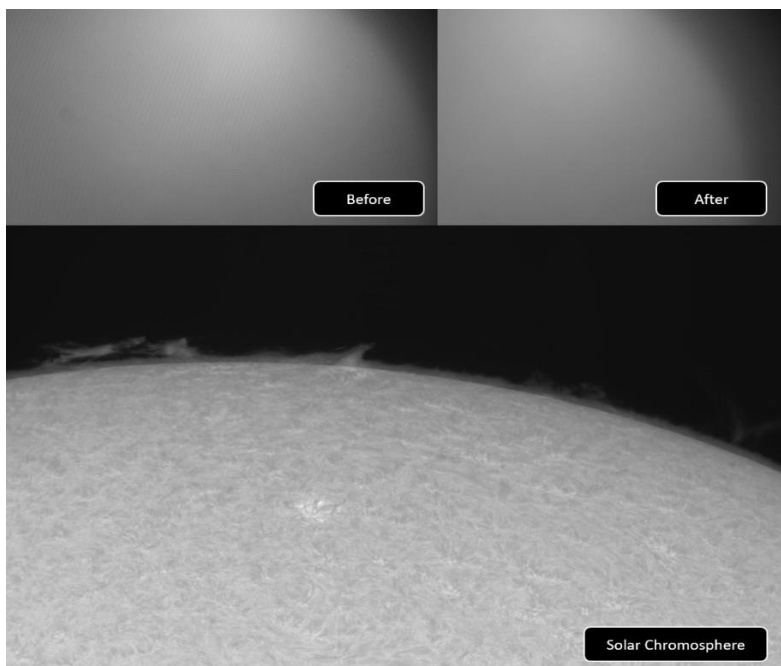
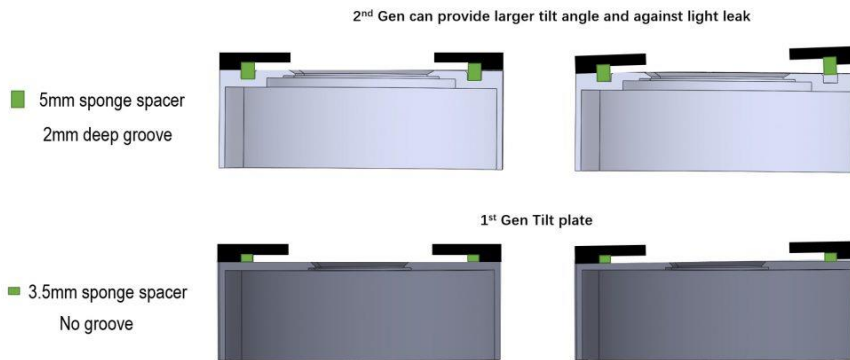

## Passive Cooling System

Solar cameras working in daylight, temperature could be much higher than night. Heat of global shutter sensors will be a problem, especially some big format like IMX432. Player One add a new feature called Passive Cooling System to conduct the heat from the sensor out.

Passive Cooling System (PCS for short) connect the sensor board and camera shield, it can move the heat fast to camera body. In testing, IMX432 sensor with PCS, the temperature will be 10°C-15 °C lower than without PCS.

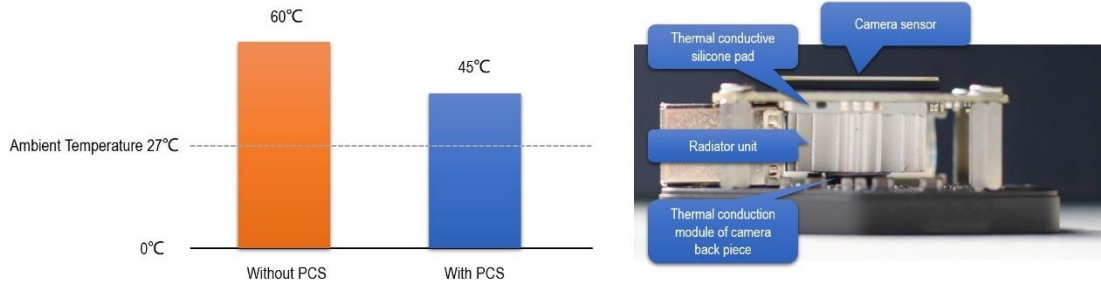

## 256M DDR3 Cache

Player One Astronomy cameras are the first one who adopts the DDR3 cache in all planetary cameras in the world! It helps stabilize and secure data transmission, it effectively avoids frame dropping and greatly reduces readnoise.

With the DDR3 cache, the camera does not have high demands on computing needs any longer, it will still have excellent performance even if it is connected to a USB 2.0 port.

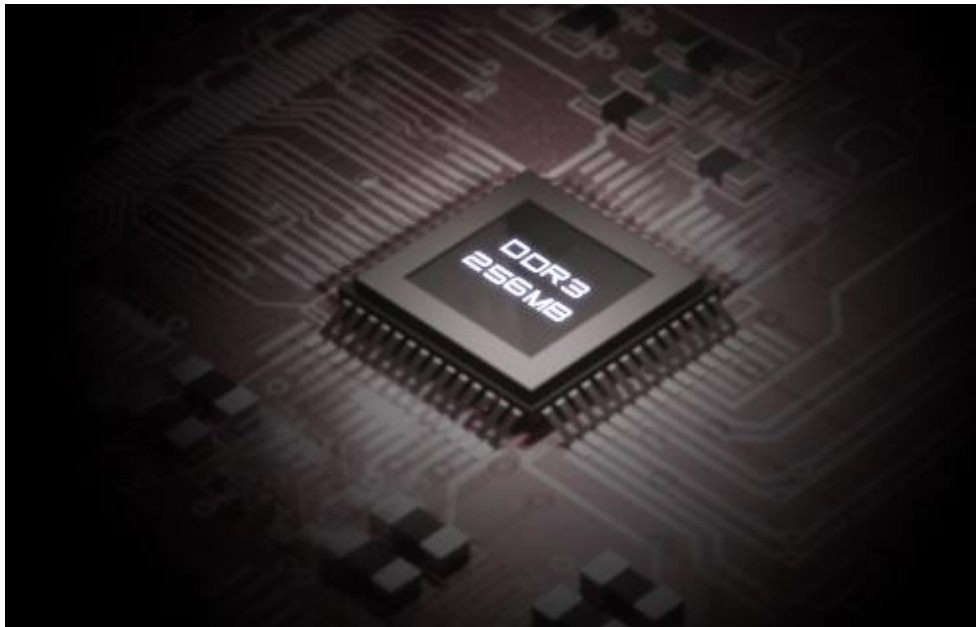

## DPS technology

The planetary cameras from Player One Astronomy have DPS (Dead Pixel Suppression) technology. The DPS analyses many dark frames to find out those fixed abnormal pixel and record the map in camera memory. In imaging, each exposure frames, those position of dead pixels will be given a median value according to the active pixels around that abnormal pixel.



## Overvoltage and overcurrent protection mechanism

Player One cameras produced by the number one player ensures the safety of your camera and other equipment through overvoltage and overcurrent protection mechanisms.

## Data Port

When the camera is connected to the USB3.0 interface and full-resolution preview is used, it can reach 84 FPS in RAW8 mode (12bit ADC). When recording images, since the actual writing speed will be affected by the writing speed of the hard disk itself, when the hard disk writing speed is slow, the recording may not reach the theoretical speed. It is recommended that you use a high-quality solid state drive to record data to give full play to the performance of the camera.

Use the ST4 guide cable to connect the camera and the AUTO GUIDE port of the equatorial mount to do guiding.

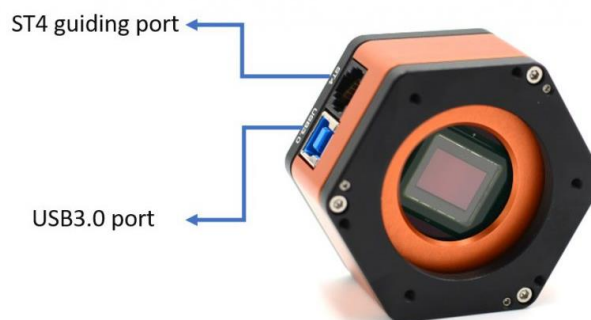

# Performance

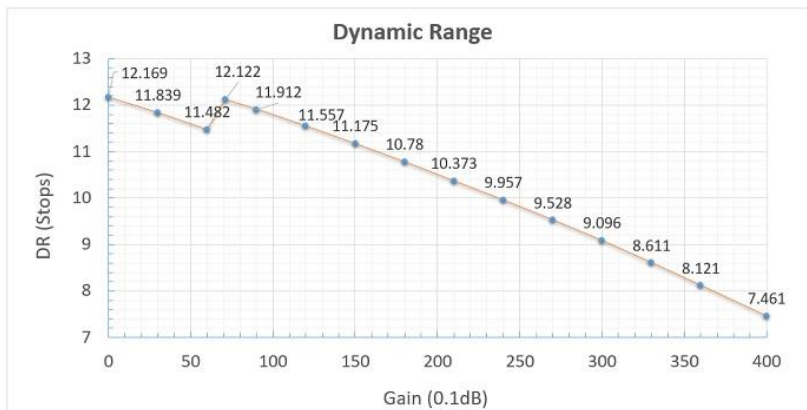
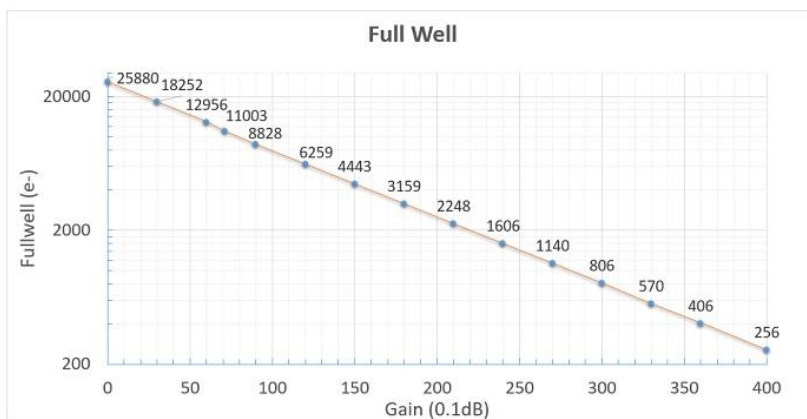
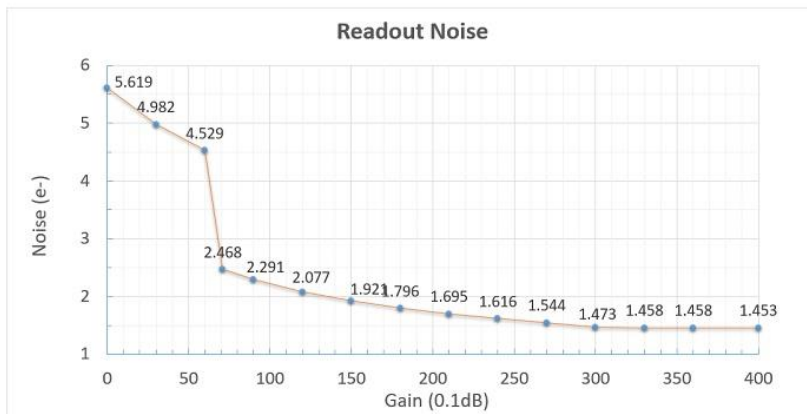
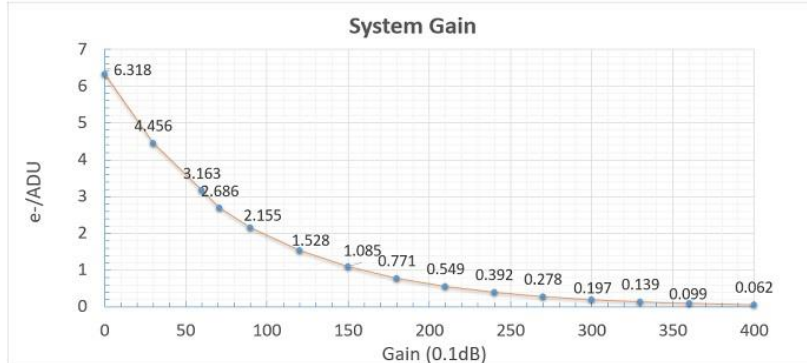

## Readout Noise

Regarding readout noise, we solemnly promise that all values are obtained from actual tests. And for users, you could use Sharpcap 4 for testing. SC4 has a function called **Sensor Analysis**, provide a very simple way to test readout noise.

We wrote a tutorial on our website: <https://player-one-astronomy.com/service/manuals/>  
After many rigorous readout noise tests, this camera can reach a low readout noise of 1.45e at a gain of 380.

If you are interested in readout noise testing, you may try it yourself, which is very simple.

## QE Curve

Absolute Peak Value is about 79%.

### IMX429 QE Curve

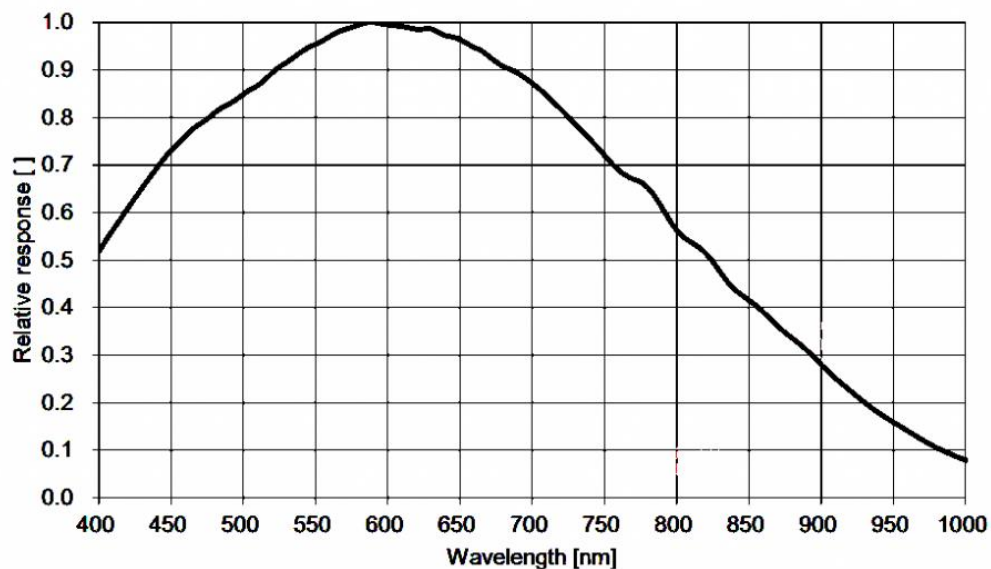

## HCG Mode

The Apollo-M MINI camera has a unique HCG mode. The HCG mode can greatly reduce the readout noise and retain the same high dynamic range as the low gain.

## Mechanical Drawing

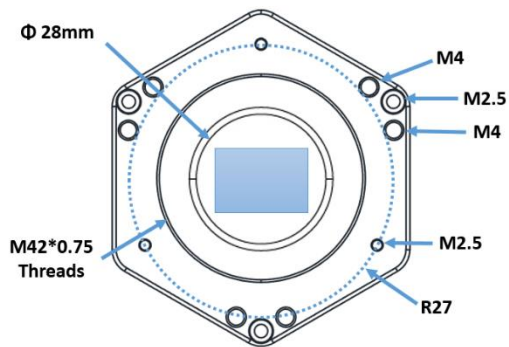
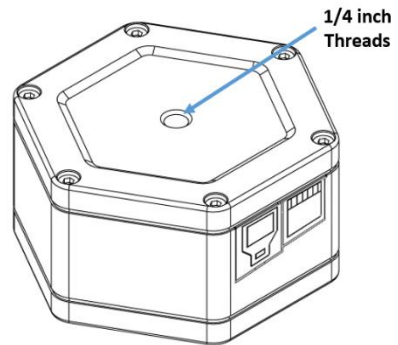
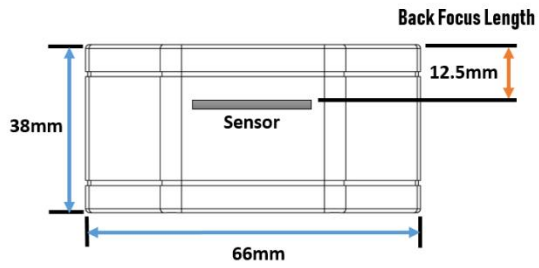

## Package List



# Camera Package

<p><b>1</b></p>  <p>Camera and T-mount</p>	<p><b>2</b></p>  <p>USB3.0 Cable</p>	<p><b>3</b></p>  <p>ST4 Cable</p>
<p><b>4</b></p>  <p>M2 Hexagonal wrench</p>	<p><b>5</b></p>  <p>1.25" Cover</p>	<p><b>6</b></p>  <p>Air Blower</p>

## Warranty & Shipping Policy

### Payment method

We provide *PayPal* and *PayPal checkout* on our website.

### Shipping and Delivery

#### Shipping Fee:

- Amount  $\geq$  299USD: free express shipping
- Amount  $<$  299USD: 29.9USD for express shipping

#### Shipping Services:

- We usually use DHL, UPS, FedEx, TNT for shipping.
- Make sure your email is correct, we maybe will contact with you through emails in case of emergency.

If customer wants to designate a shipping company or has special requirement, please send an email to [support@player-one-astronomy.com](mailto:support@player-one-astronomy.com) and tell us your detailed requirement.

#### Shipping time:

- Usually 7-14 days.
- Tracking number will be updated in 3 days after paid.

For orders from areas where transportation is not easy, such as islands, town in mountainous regions, delivery time will be slightly longer.

Please send an email to [support@player-one-astronomy.com](mailto:support@player-one-astronomy.com) immediately, if the following occurs:

- Shipping delayed or has some abnormal information.
- The packing is badly damaged on arrival, take pictures and do not sign.

### Tax

- The price on our website without tax.
- Please note that buyers are liable to charge tax involved, such as Import tax, VAT, customs handling fee, etc.
- Those fees possibly will be collected at the time of delivery by courier.

For best experiences, we recommend customers to purchase our products form local dealers.

### After-sales Service

#### Warranty Policy

2-year free warranty (time start from delivered) for Player One products. If the product has any issue, please send the image or video and description to [support@player-one-astronomy.com](mailto:support@player-one-astronomy.com) for further check to confirm.

- Purchase from Player One official online store, we will provide warranty service directly.
- Purchase form dealer, we will provide warranty service through dealer.



Repair in warranty, customer only pay the shipping fee of shipping back the product to us or dealer, and no other extra fees.

### **Replacement Policy**

You can request our Replacement Service:

- √ Within 30 calendar days of receiving the product if the product does not match the original description of the product in one or more significant respects.
- √ Within 30 calendar days of receiving the product if the product suffers performance failure.

Please contact our After-Sales team by email to [support@player-one-astronomy.com](mailto:support@player-one-astronomy.com) within 30 calendar days of receiving the products. Player One shall be responsible for the two-way replacement freight for any products sent in for replacement due to performance faults.

### **Warranty and Replacement Policy Exceptions:**

- × Warranty service time or replacement service time expired.
- × Legal proof-of-purchase, receipts, or invoices are not provided, or are reasonably believed to have been forged or tampered with.
- × A product sent to Player One for replacement does not include all original accessories, attachments and packaging, or contains items damaged by user error.
- × A product is found to have no defects after all appropriate tests are conducted by Player One.
- × Any fault or damage of the product is caused by unauthorized use or modification of the product, including exposure to moisture, entry of foreign bodies (water, oil, sand, etc.) or improper installation or operation.
- × Product labels or serial numbers show signs of tampering or alteration.
- × Damage is caused by uncontrollable external factors, including falling down, fires, floods, or lightning strikes, etc.
- × Proof of damage during transit issued by the carrier cannot be provided.
- × Other circumstances stated in this policy.

In those situations, repair the product might have extra cost, we will estimate cost and email customer to know the information before send product back.